

NO.	DATE	REVISIONS
1	02/01/2024	Per City of Marco Island, Corrections Report dated February 07, 2024
2	03/01/2024	Per City of Marco Island, Corrections Report dated March 01, 2024
3	08/01/2024	Per City of Marco Island, Corrections Report dated August 01, 2024

ACAD FILE NAME:	Cover
ABB PROJECT #	23-0019
PLOT VIEW / LAYOUT	L1 COVER
SHEET	01
OF	06
ACAD FILE #	13639

SITE DEVELOPMENT PLAN AMENDMENT (SDPA) LANDSCAPE PLANS FOR: MARCO ISLAND PICKLEBALL CENTER

SECTION 16 , TOWNSHIP 52 S, RANGE 26 E, COLLIER COUNTY, FLORIDA

PROPERTY ZONING: P, REC

PROPERTY FOLIO NUMBER: 58970160006

LEGAL DESCRIPTION:

MARCO BCH UNIT 25 THAT PORT OF TR C & THAT PORT OF TR R-A OF REPLAT OF UNIT 25 DESC AS FOLL: BEG NW CNR TR C MARCO BCH UNIT 25, E 275FT ALG S R/W SR-92, S 495FT, W 257.83FT, N 385FT, W 17.17FT, N 110FT TO POB OR 917 PG 213

SITE ADDRESS: 1275 SAN MARCO ROAD, MARCO ISLAND, FL 34145

PLAN STAGE:

1st SDPA Submittal: February 1, 2024

2nd SDPA Submittal: April 3, 2024

3rd SDPA Submittal: August 27, 2024

SHEET INDEX	
SHEET #	SHEET TITLE
L1	COVER SHEET
L2	SURVEY & DEMOLITION PLAN
L3	LANDSCAPE PLAN
L4	LANDSCAPE DETAILS
L5	LANDSCAPE SPECIFICATIONS
L6	IRRIGATION PLAN
L7	SHADE CANOPY DETAILS

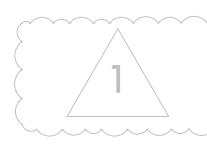

PROJECT LOCATION MAP

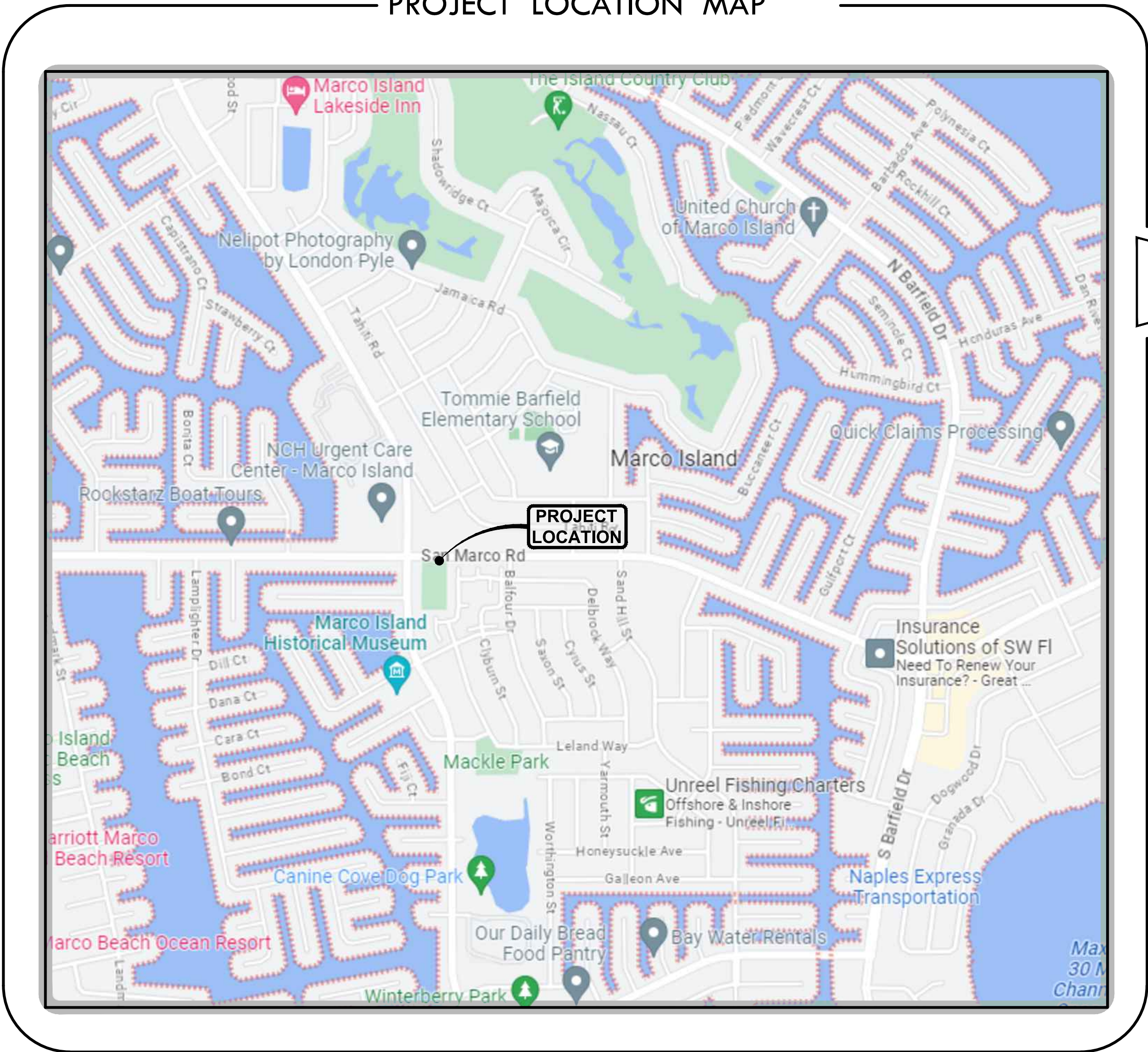

PROJECT AERIAL MAP

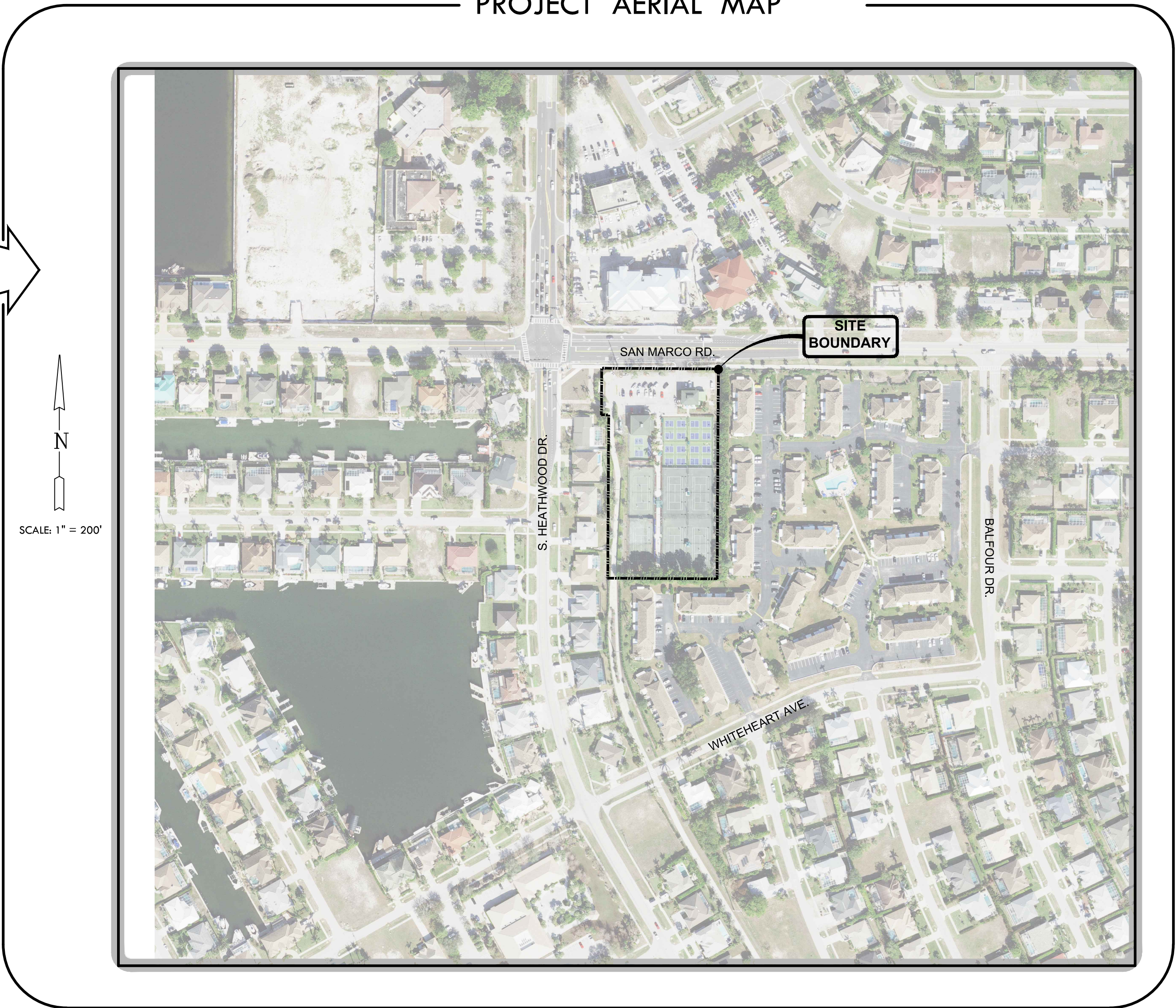

LANDSCAPE DEMOLITION SCHEDULE			
COMMON NAME	TO REMAIN	TO BE REMOVED	TO BE RELOCATED
LARGE CANOPY TREE			
MEDIUM CANOPY TREE			
PALM TREE			
SHRUB MASS			

NOTE:
ALL EXISTING PLANT MATERIALS TO REMAIN UNLESS SHOWN IN RED ON THIS PLAN.

NOTE:
EXISTING CODE REQUIRED PLANTING FOR THE SDP MEETS CODE OR WILL BE BROUGHT UP TO CODE.



Client Name:
CITY OF MARCO ISLAND
50 BALD EAGLE DRIVE
MARCO ISLAND, FL 34145

PROJECT NAME:
MARCO ISLAND
PICKLEBALL CENTER

DRAWING TITLE:
EXISTING CONDITIONS

DESIGNED BY: LJA
DRAWN BY: BCG
CHECKED BY: BCG
REVIEWED BY: BCG
HOR. SCALE: 1"=30'
VERT. SCALE: N/A

NO.	DATE	DESCRIPTION
1	Rev. No. 2 - Per City's Plan Corrections Report dated July 18, 2024	
2	Rev. No. 3 - Per City's Plan Corrections Report dated August 20, 2024	

ACAD FILE NAME:
Landscape
ABB PROJECT #
23-0019
PLOT VIEW \ LAYOUT
L2 SURVEY
SHEET 02
OF 07
ACAD FILE #
13639

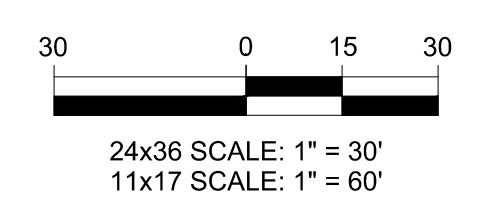

PERIMETER BUFFERING (Per LDC Sec. 30-441)

NORTH - SAN MARCO ISLAND (100' R.O.W)
 REQUIRED: TYPE C BUFFER - 15' WIDE, TREES @ 30'
 275lf - 25lf (DRIVE) / 30' = 8 TREES REQUIRED
 275lf - 25lf (DRIVE) / 4' = 125 SHRUBS REQUIRED

EAST - RESIDENTIAL
 REQUIRED: TYPE B BUFFER - 10' WIDE, PER VARIANCE (VP-24000099)
 TREES @ 25'
 495 lf / 25' = 19 TREES REQUIRED
 495 lf / 4' = 123 SHRUBS REQUIRED

SOUTH - RESIDENTIAL - 15' WIDE, TREES @ 25'
 REQUIRED: TYPE B BUFFER REQUIRED
 258lf - 34lf (U.E.) / 25' = 9 TREES REQUIRED
 258lf - 34lf (U.E.) / 4' = 56 SHRUBS REQUIRED

WEST - RESIDENTIAL
 REQUIRED: TYPE B BUFFER - 15' WIDE, TREES @ 25'
 All Existing Buffer Plantings to Remain

VEHICULAR USE AREAS (Sec. 30-439)

At least ten percent of the amount of vehicular use area onsite shall be devoted to interior landscaping areas. One tree shall be provided for every 250 square feet of required interior landscaped area.

Total Planned VUA = 6,149 square feet
 Total Landscape Required = 615 square feet
 Total Landscape Provided = 800 square feet
 Total Trees Required = 2
 Total Trees Provided = 4

MIN. LANDSCAPE REQUIREMENTS (Sec. 30-440)

One canopy tree per 3,000 square feet of pervious site area excluding preserves. This is in addition to other landscaping requirements.

Total Pervious Site Area = 35,370
 Total Canopy Trees Required = 12
 Total Canopy Trees Provided = 15

PLANT MATERIAL STANDARDS (Sec. 30-435)

- NATIVE PLANT MATERIAL:
- MIN. 50% REQUIRED = 100% NATIVE TREES PROVIDED
- MIN. 50% REQUIRED = 100% NATIVE SHRUBS PROVIDED



General Landscape Notes:

- The Landscape Contractor shall grade planting beds, as required, to provide positive drainage and promote optimum plant growth.
- All recommended trees and plant materials will be graded as Nursery Grade No. 1 or better as outlined by the Florida Department of Agriculture and Consumer Services, Division of Plant Industry "Grades and Standards for Nursery Plants", 7th Edition, 1998 as revised from time to time.
- All planting shall be done in accordance with the Florida Nurserymen's and Growers' Associations approved practices.
- All plants shall be fertilized with Agriform 20-10-5 tablets as per the manufacturers specifications in conjunction with note # 5.
- The planting soil shall be the approximate proportions as follows: 50% sand and 50% organic material consisting of native peat, well-decomposed sawdust, leaf mold and top soil. It shall provide a good pliable and thoroughly mixed medium with adequate aeration, drainage and water-holding capacity. It shall also be free of all extraneous debris, such as roots, stones, weeds, etc.
- All planting areas shall receive a 3" layer of pine straw, which is to be watered-in after installation.
- The plant material schedule is presented for the convenience of the Landscape Contractor. In the event of a discrepancy between the plan and the plant key, the plan shall prevail.
- Plants shall meet size, container, and spacing specifications. Any material not meeting specifications shall be removed and replaced at the contractor's expense.
- Landscape Contractor shall have a pre-construction review of plans with Landscape Architect prior to ordering plant material, to verify plans are current, and that no changes are necessary. Contractor shall also schedule a walk thru to allow Landscape Architect to review flagging and placement of all plant material prior to installation. These above mentioned meetings are important to the quality control of the project. Landscape Contractor understands that if work commences without these meetings, that the owner and Landscape Architect have the ability to make field changes to the plans at the Landscape Contractor's expense.
- The Landscape Contractor shall be responsible for examining fully both the site and the bid documents. Discrepancies in the documents or the actual site conditions shall be reported to the Landscape Architect in writing at the time of discovery. No account shall be made after contract completion for failure to report such condition, or for errors on the part of the Landscape Contractor at the time of bidding.
- The Landscape Contractor shall be responsible for securing all necessary applicable permits and licenses to perform the work set forth in this plan set and the specifications.
- Plant material shall be bid as specified unless unavailable, at which time the Landscape Architect will be notified by telephone and in writing of intended changes.
- Any and all questions concerning the plan set and/or specifications shall be directed to Agnoli, Barber, & Brundage, Inc. (ABB) (239) 597-3111.
- There shall be no additions, deletions or substitutions without the written approval of the Landscape Architect.
- The Landscape Contractor shall guarantee, in writing, plant survivability for a period of twelve (12) months from final acceptance by the Landscape Architect.
- All dimensions to be field-checked by the Landscape Contractor prior to landscape material installation. Discrepancies shall be reported immediately to the Landscape Architect.
- All materials must be as specified on the landscape plan. If materials or labor do not adhere to specifications, they will be rejected by the Landscape Architect with proper installation carried out by Landscape Contractor at no additional cost.
- All permits necessary are to be provided by the installing contractor unless otherwise specifically stated in the specifications.
- No contractor identification signs shall be permitted on the project, except for the project information signs.
- Existing sod shall be removed as necessary to accommodate new plantings.
- Any existing sod areas that are unnecessarily disturbed during the landscape installation shall be resodded to match existing.
- The Landscape Contractor will be responsible for the collection, removal, and proper disposal of any and all debris generated during the installation of this project.

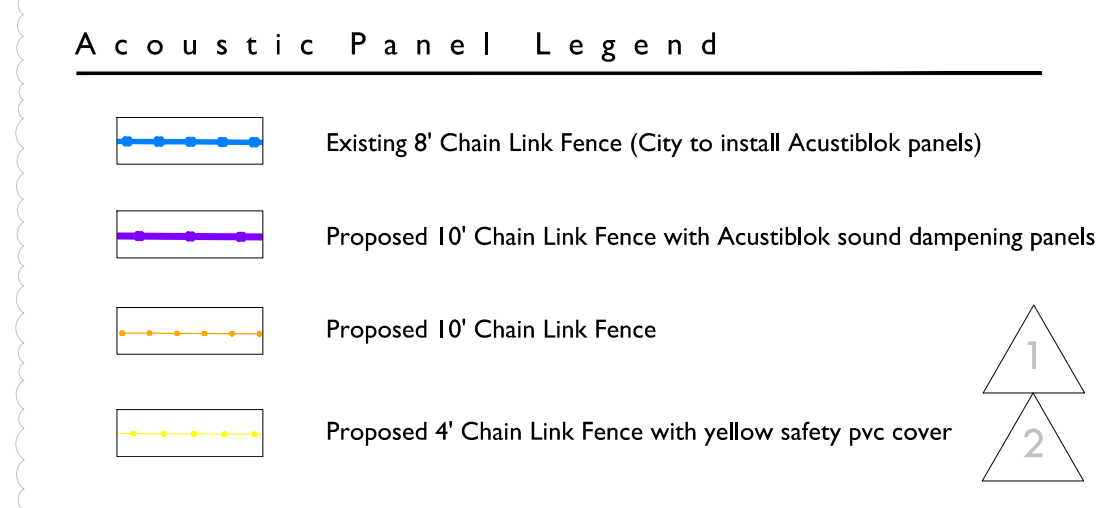

NOTE:
 All proposed chain link fence to be 10' maximum height, black, vinyl coated chain link. The post, top rail, bottom rail, and other hardware to have a black powder coated finish.

NOTE:
 The new pickleball courts west of the central sidewalk to receive new fencing. Existing tennis and pickleball court fencing east of the central sidewalks shall remain. The entire perimeter of the chain link fence to receive Acustiblok sound dampening panels.

PLANT SCHEDULE

SYMBOL	CODE	QTY	BOTANICAL NAME	COMMON NAME	CONT.	CAL.	SIZE	SPREAD	NATIVE	SPACING
TREES										
	CE7	17	Conocarpus erectus	Green Buttonwood Standard	45 gal.	2' Cal.	10'-12' oah	4'-6'	Native	
	SM4	3	Swietenia mahagoni	Mahogany	65 gal.	2' Cal.	14'-16' oah	6' - 8'	Native	
PALM TREES										
	RE9	15	Roystonea elata	Florida Royal Palm	FG		18' Min. Ht.		Native	
SHRUBS										
	CR2	235	Clusia rosea	Autograph Tree	10 gal.		48" Ht.		Native	
	PM2	49	Podocarpus macrophyllus	Yew Pine	3 gal.		24"x48"			36' o.c.
GROUND COVERS										
	LM	119	Liriope muscari 'Big Blue'	Big Blue Lilyturf	1 gal.		24"x24"			
	TA2	447	Trachelospermum asiaticum	Asian Jasmine	1 gal.					
SOD/SEED										
	SS2	13,019 sf	Stenotaphrum secundatum 'Florim'	Florim St. Augustine Sod	sod					

REFERENCE NOTES SCHEDULE

SYMBOL	DESCRIPTION	QTY	DETAIL
	Crushed Shell - Installed over weed fabric	3,485 sf	2024-07-23 14:28

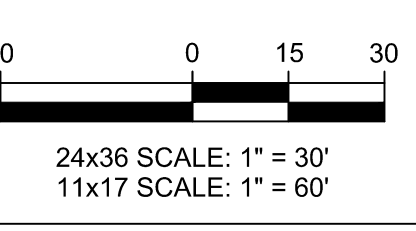

EMPLOYEE-OWNED. CLIENT FOCUSED.
 Engineering Firm License: LBS669

Collier County:
 7400 Trail Boulevard, Suite 200
 Naples, FL 34109
 P: 239.464.2203

CLIENT NAME:
**CITY OF MARCO ISLAND
 50 BALD EAGLE DRIVE
 MARCO ISLAND, FL 34145**

PROJECT NAME:
**MARCO ISLAND
 PICKLEBALL CENTER**

DRAWING TITLE:
LANDSCAPE PLAN

DESIGNED BY: LJA
 DRAWN BY: BCG
 CHECKED BY: BCG
 REVIEWED BY: BCG
 HOR. SCALE: 1"=30'
 VERT SCALE: 1"=XXX'
 DATE: August 2024

ACAD FILE NAME:
Landscape

ABB PROJECT #
23-0019

PLOT VIEW \ LAYOUT
L3 LANDSCAPE

SHEET **03**
 OF **07**

ACAD FILE #
13639

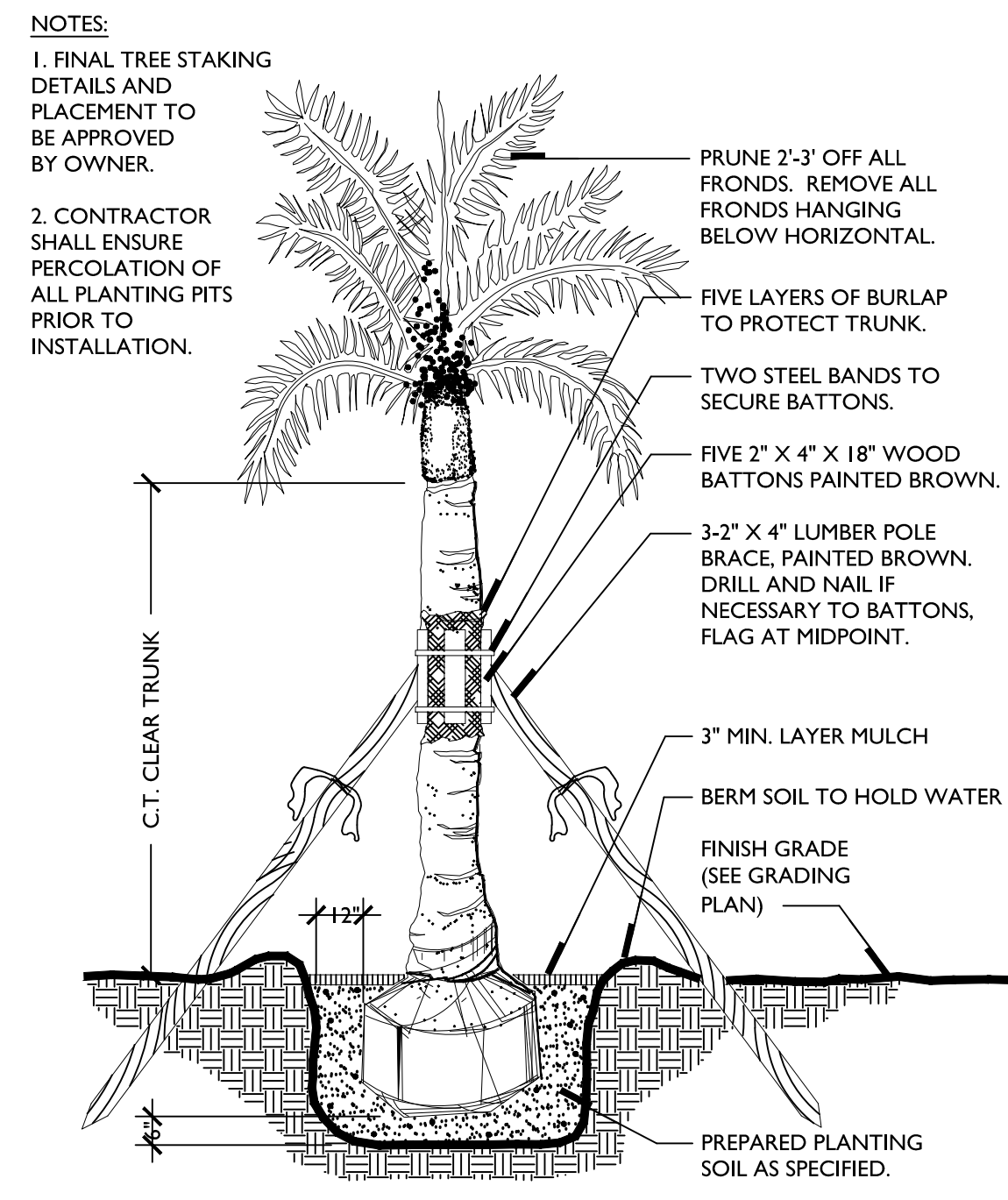

1 SMALL PALM TREE DETAIL
SECTION Scale: N.T.S.

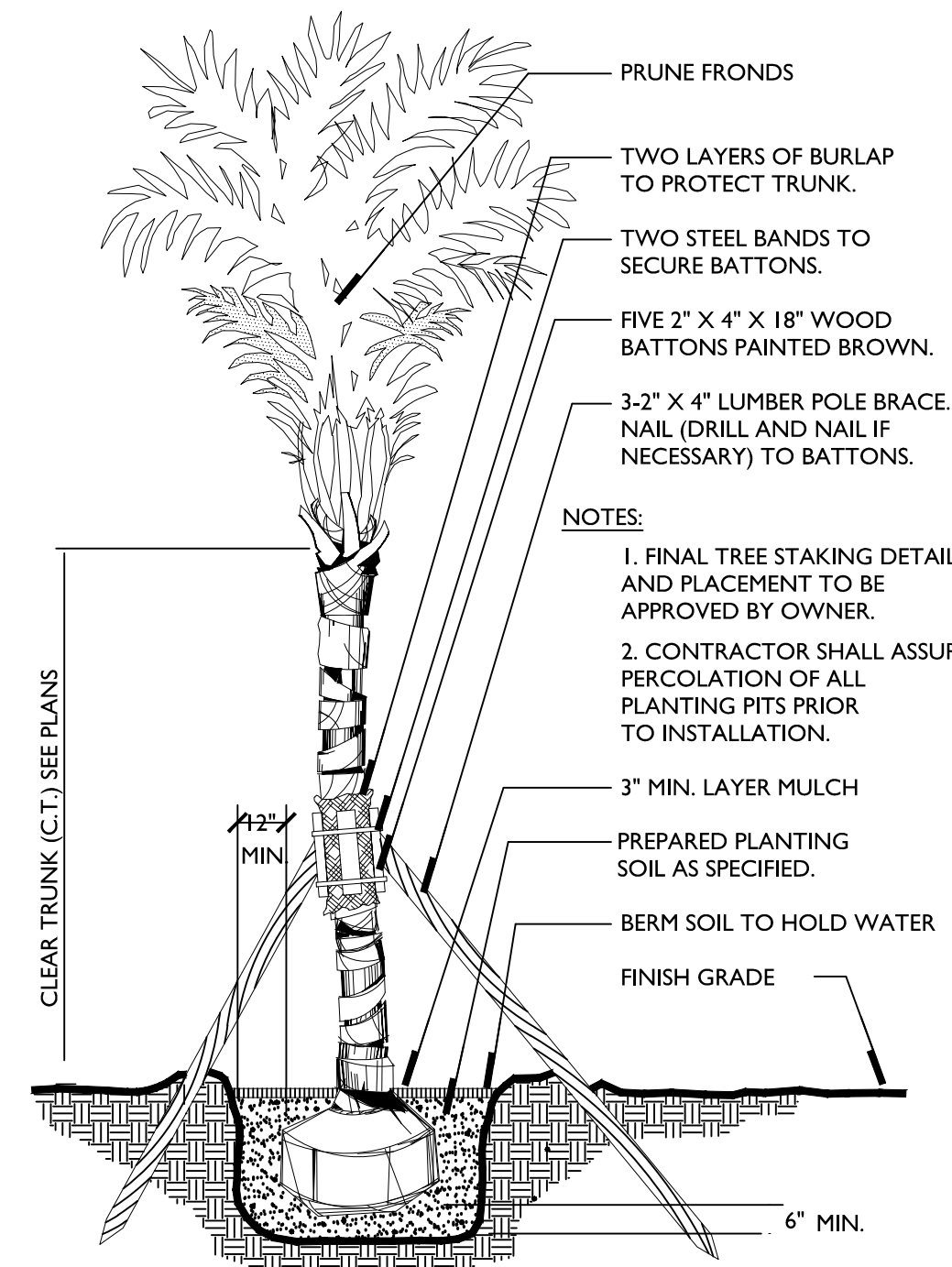

2 LARGE PALM TREE DETAIL
SECTION Scale: N.T.S.

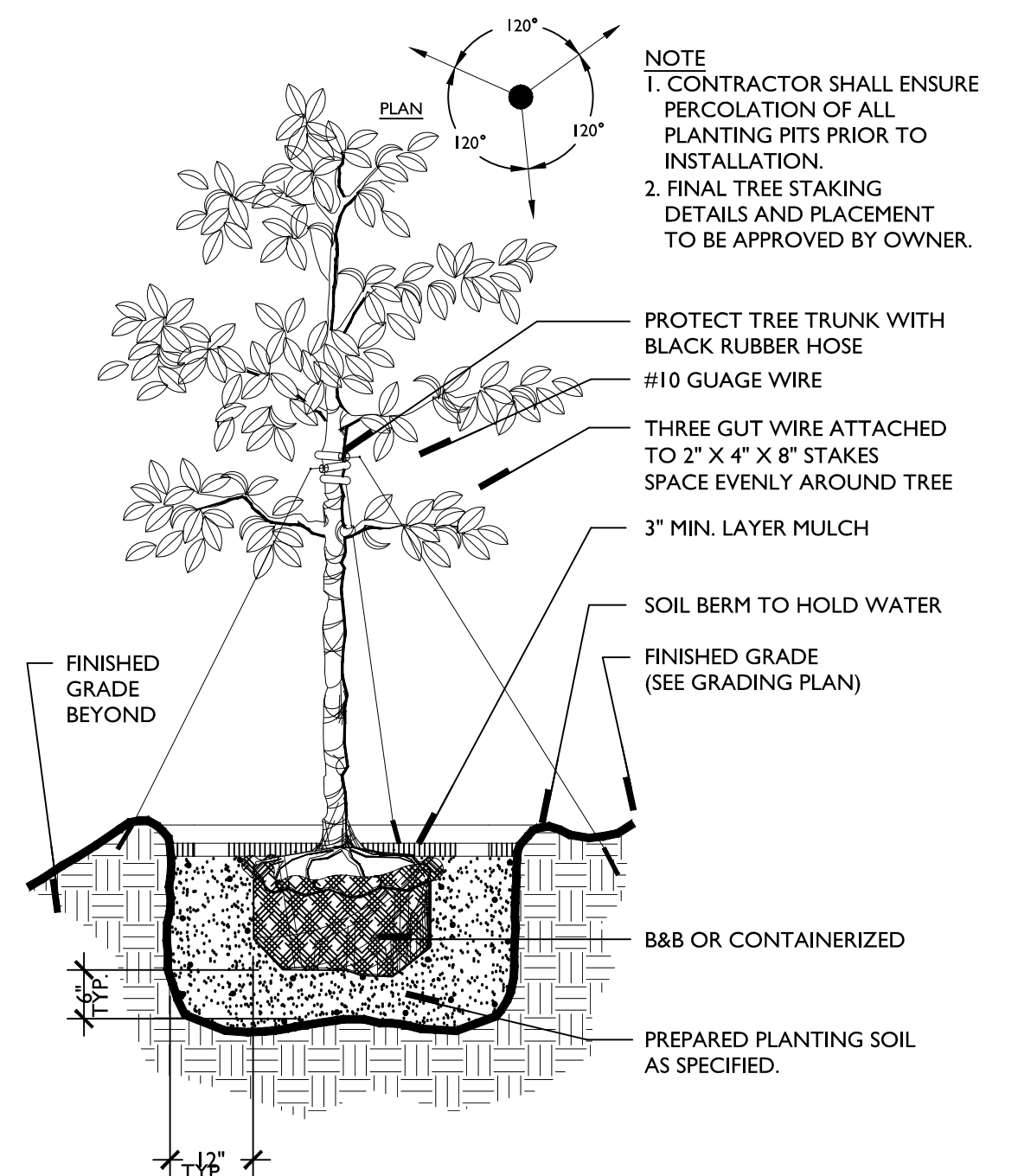

3 SMALL TREE STAKE DETAIL
SECTION Scale: N.T.S.

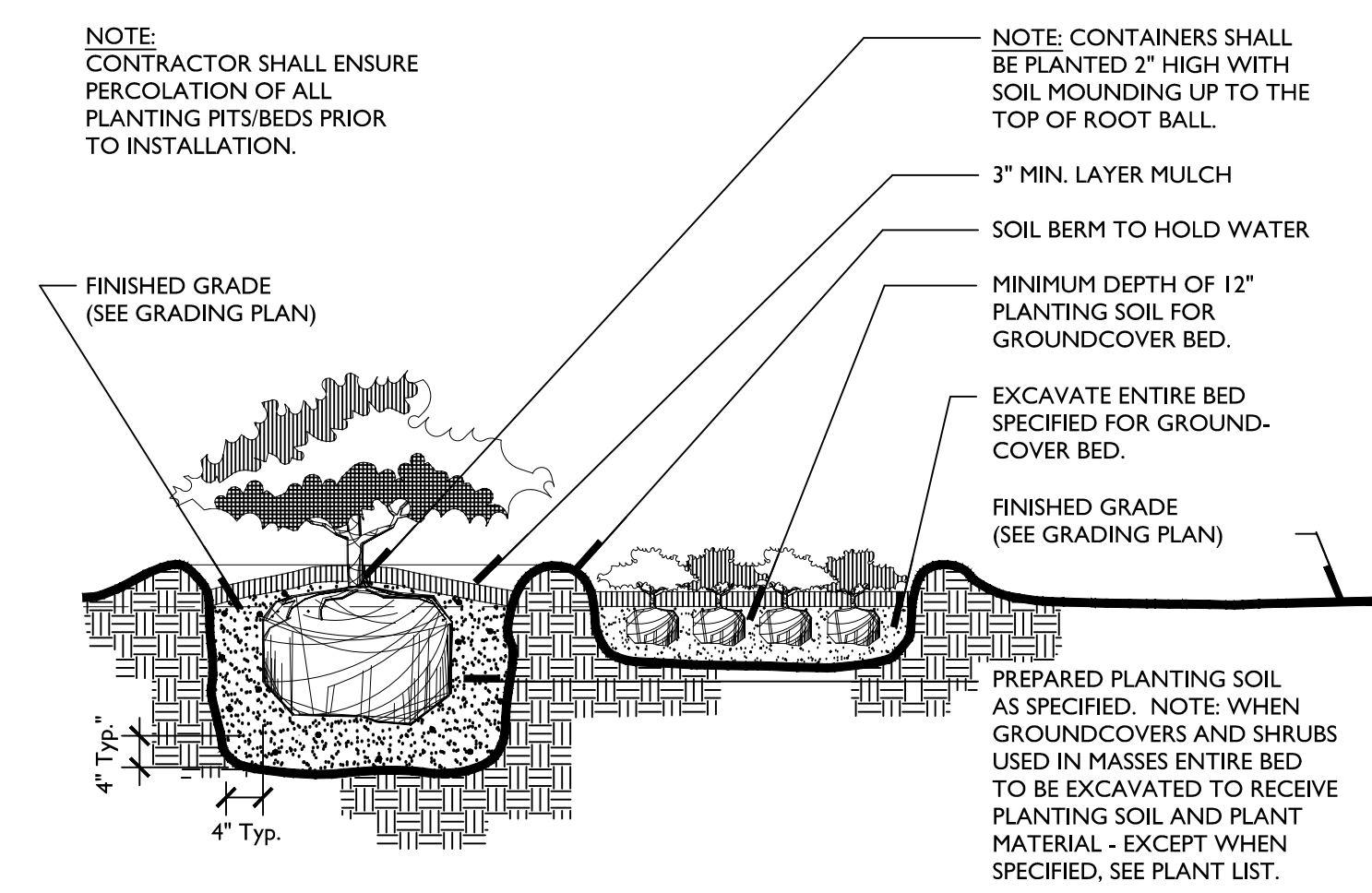

4 CONTAINER AND GROUND COVER DETAIL
SECTION Scale: N.T.S.

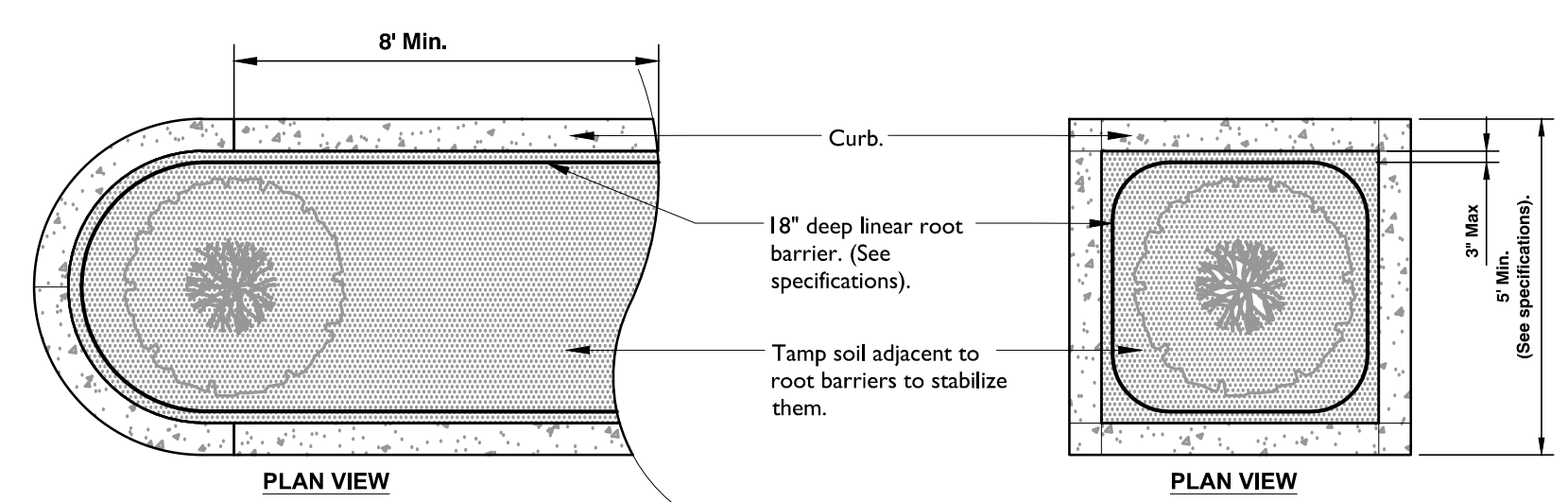

Notes:
1- Root barriers shall be installed per manufacturer's specifications and recommendations.
2- Root barriers shall be installed when root ball is located within 8' of pavement.

5 ROOT BARRIERS - PARKING LOT ISLANDS
3/8" = 1'-0"

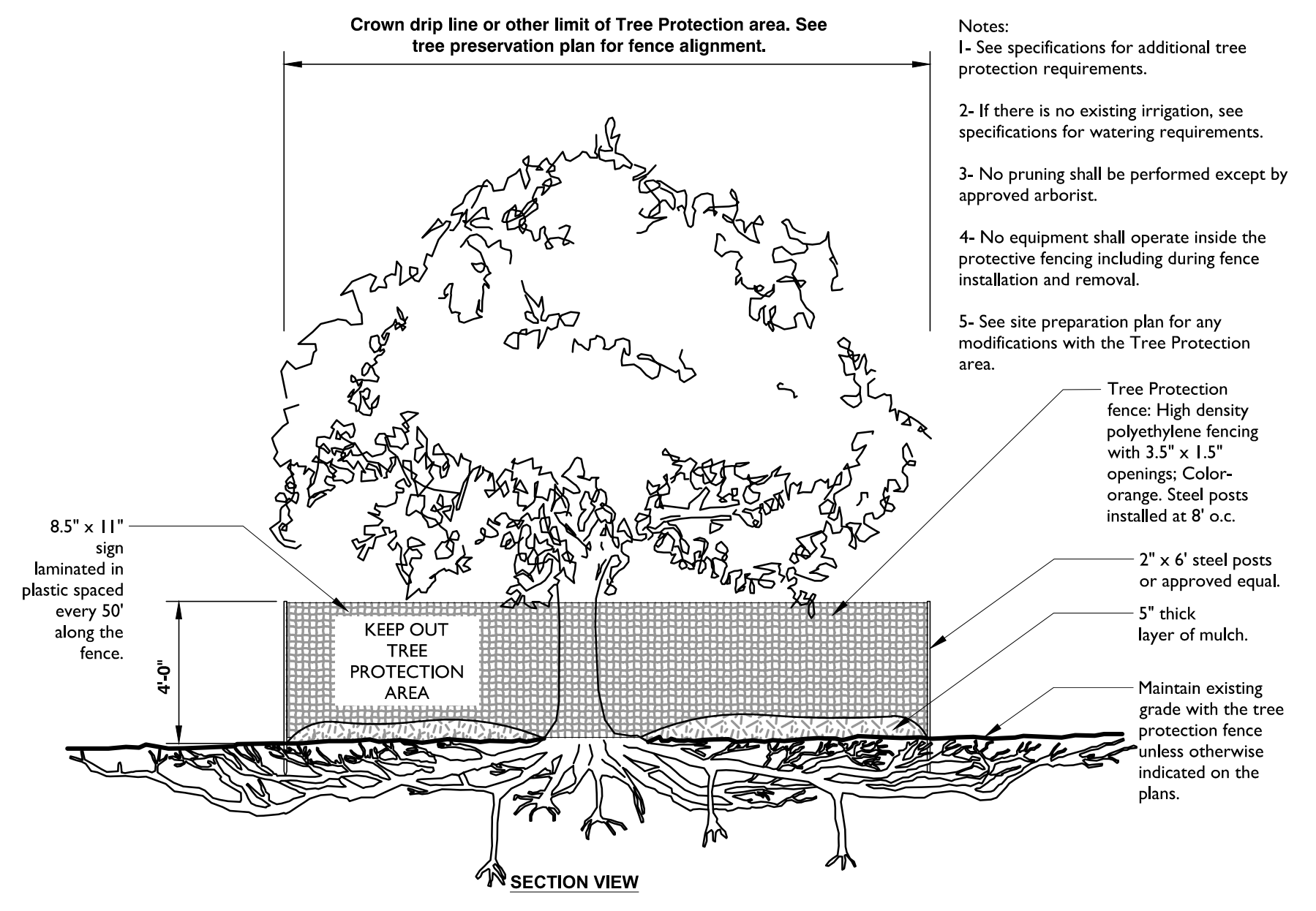

6 TREE PROTECTION
1/4" = 1'-0"

General Planting Notes

PERFORMANCE:

- The Landscape Contractor is to conform to all applicable Local, Community and County Codes.
- The Landscape Contractor is responsible to report all errors, omissions and discrepancies to LJA Engineering, Inc. (LJA).
- ABB to flag all large and/or specimen material and all bedlines prior to installation.
- The Landscape Contractor is to alert LJA of any site changes that are contrary to the plan.
- The Landscape Contractor is to contact LJA before completion their proposal to discuss Large and/or specimen materials.
- Landscape contractor is responsible to remove all debris and trash from the job site upon completion.
- Care shall be taken not to disturb or damage any underground utilities. Any damages to these facilities during the planting operations shall be repaired at the expense of the guilty Contractor in a manner approved by the appropriate authority.

EXISTING MATERIALS:

- All plant material located outside building envelope shall remain protected throughout the duration of construction.
- General Contractor is responsible to have all exotic plant and noxious vines be removed and treated to prevent growth during site clearing.

- Trim and remove all dead pine tree limbs, palmetto fronds, etc.
- All weeds, patches, of grass, or dead material shall be removed from the lot or treated to prevent growth.
- Cautions shall be exercised protect all existing sod, plant beds and irrigation systems on adjacent properties. Any damage to existing sod, plant beds or irrigation systems shall be replaced or repaired to their original state by the home builder at no additional cost to the adjacent property owner/resident.

PLANT MATERIAL:

- All building construction debris or foreign material shall be removed from planting areas and replaced with acceptable top soil by Owner / Builder.
- All plant material to be Florida grade #1 or better, as defined in Grades and Standards for Nursery Plants, State Plant Board of Florida. Plant material noted as specimen shall be Florida fancy grade.
- All finished site grading to be completed by Owner / Builder.

MULCH:

- All planting beds to be top dressed with pine straw or approved organic mulch to a minimum depth of 3 inches. No more than 25 percent by volume of the mulch used on a site may be cypress mulch.

LAWN:

- All lawn areas to be St. Augustine Turf unless otherwise noted.
- Lawn areas to be fine graded prior to installation. Newly laid sod to be solid, tightly butted and rolled upon completion of installation.
- Landscape contractor is responsible to lay sod up to all front street edge beyond front property line and all lake edge banks where applicable.
- Landscape contractor is responsible to hand rake all rock and other unwanted debris and trash prior to the installation of sod.
- Landscape contractor to lay sod up to all property lines, existing native areas and designated bedlines.

THESE DRAWINGS DO NOT INCLUDE COMPONENTS FOR CONSTRUCTION SAFETY.
CALL "SUNSHINE 811" BEFORE DIGGING
Dial 811 or visit www.sunshine811.com

LJA
EMPLOYEE-OWNED.
CLIENT FOCUSED.
Engineering Firm Number: 32200
Surveying Firm License: LB8569

Collier County:
7620 Trail Boulevard, Suite 200
Naples, FL 34108
P: 239.777.1111
F: 239.646.2203

CLIENT NAME:
CITY OF MARCO ISLAND
50 BALD EAGLE DRIVE
MARCO ISLAND, FL 34145

PROJECT NAME:
MARCO ISLAND PICKLEBALL CENTER

DRAWING TITLE:
LANDSCAPE DETAILS

DESIGNED BY: LJA
DRAWN BY: BCG
CHECKED BY: BCG
REVIEWED BY: BCG
HOR. SCALE: N/A
VERT. SCALE: N/A
DATE: August 2024

NO. DATE REVISIONS

ACAD FILE NAME:
Landscape

ABB PROJECT #
23-0019

PILOT VIEW \ LAYOUT
L4 DETAILS

SHEET **04**
OF **07**

ACAD FILE #
13639

LANDSCAPE INSTALLATION SPECIFICATIONS:

PART 1 - GENERAL

1.1 SCOPE

- A. Furnish all labor, materials, supplies, equipment, tools, and transportation, and perform all operations in connection with and reasonably incidental for a complete installation of the planting. Guarantee/Warranty all plantings as identified on the drawings and specified herein. Landscape work includes:
 1. Site Preparation for Planting: including removal of existing plant material.
 2. Planting of Trees, Shrubs, Groundcover, Bedding Plants, Specialty Plantings
 3. Soil testing, amendments and topsoil placement
 4. Fertilizers, herbicides and pesticides
 5. Miscellaneous items such as mulch, staking and guying, and edging.
- B. Related Sections: Other work included in the construction related to this section include:
 1. Irrigation - Section 02813
 2. Lawns - Section 02910
 3. Grounds Maintenance Services - Section 02920

1.2 GENERAL CONDITIONS

- A. All scaled dimensions are approximate. Check and verify all site dimension and receive Owner's approval prior to proceeding with the work under this section.
- B. Coordinate installation of all plant materials to avoid interference with other construction.
- C. Keep the premises clean and free of excess equipment, materials and debris incidental to the work.
- D. Protect work and work of others at all times in the performance of the work.
- E. Carefully note all finish grades before commencing work. Restore any finish grade changed during course of this work to its original or intended grade.

1.3 SUBMITTALS

- A. If this project includes Conditions of the Contract and Division I Specifications, submit all documents in accordance with their requirements.
- B. Provide a photograph of each species and specific form of tree or shrub in the planting legend. Each photo shall be in color with a scaled object next to the plant. Label each photograph with the following: Botanical Name, Common Name, Size, Nursery Name, Cost. Submit all photographs to the landscape architect for review and approval a minimum of two (2) weeks prior to beginning of landscape work.
- C. Product literature with certified analysis (if appropriate) for the following: Soil amendments, pesticides, herbicides, growth stimulants, etc.
- D. Firm Qualifications including: Name and Address of Company, Years of Operation, Owner Name, Project Manager Name, Job Supervisor Name, list of five (5) projects of similar size completed within last two (2) years with owner contact information.
- E. Testing reports from qualified independent testing agency (State Extension Service Accepted) for the following: Existing Soils, Import topsoil, Planting soil. Soils analysis shall indicate percentages of percentages of organic matter, inorganic matter (sand, silt, clay), pH, mineral and plant nutrient including micro-nutrient content.

1.4 QUALITY ASSURANCE

- A. Provide quality, size, genus, species and variety of trees and shrubs as indicated on the plans and complying with applicable requirements of ANSI Z60.1 "American Standard for Nursery Stock."
- B. Tree and Shrub material shall meet the minimum requirements of Florida No. 1 as specified by the latest edition of Florida Grades and Standards. Plants indicated as specimen shall meet the minimum requirements of "Florida Fancy" as specified by Florida Grades and Standards Part I and II.
- C. Measurements: Measure trees and shrubs according to ANSI Z60.1 with branches and trunks or canes in their normal position. Do not prune without Landscape Architects approval. Take caliper measurements 6 inches above ground for trees up to 4 inch caliper and 12 inches above ground for larger sizes. Measure main body of tree or shrub for height and spread, do not measure to tip of branching.

1.5 DELIVERIES, STORAGE AND HANDLING

- A. Packaged Materials: Deliver packaged materials in containers showing weight, analysis and name of manufacturer. Protect materials from deterioration during delivery and while stored at site. Storage of materials on site shall be maintained in a clean and orderly manner.
- B. Trees and Shrubs: Protect from sunscald, drying, sweating, whipping and other handling and tying damage. Do not bend or bind branches in such a manner as to damage the natural shape or character of the plant. Provide protective cover during deliver and at all times protect plants from wind damage. Do not drop trees or shrubs during delivery. Do not pick up trees from trunk. Any mishandling of plant material leading to damage of material shall be cause for rejection.
- C. Deliver plant material after preparations for planting have been completed. Install immediately. If planting is delayed more than six (6) hours after deliver, set plant material in shade, protect from weather and mechanical damage and protect roots from drying. Water to keep roots moist.

1.6 PROJECT CONDITIONS

- A. Utilities: Determine location of above grade and underground utilities and perform work in a manner, which will avoid damage. Contact SUNSHINE at 1-800-432-4770 at least 48 hours before digging.
- B. Excavation: When conditions detrimental to plant growth are encountered, such as rubble fill, adverse drainage conditions, obstructions, or foul smelling soils, notify Landscape Architect prior to planting.

1.7 COORDINATION AND SCHEDULING

- A. Coordinate installation of planting materials with the construction of other trades on site. Contractor shall be responsible to insure proper watering of plant material until acceptance by the owner. Do not knowingly plant trees or shrubs in locations where other construction is planned requiring the removal of the plant.

1.8 WARRANTY

- A. Warrant all Trees, Palms or Specialty Plants for a period of 1 year from the date of owner acceptance against defects including death and unsatisfactory growth (plants with more than 25% dead or damaged structure shall be removed), and for defects resulting from installation techniques contrary to those identified in the contract documents or poor conditions or health of plant from the nursery. Warranty shall be irrespective of the landscape contractors maintenance responsibilities.
- B. Warrant all Shrub, Groundcover, and Bedding plants for a period of 3 months from the date of owner acceptance against defects including death or unsatisfactory growth including disease or pest infestation.
- C. Warranty period shall begin at the date of acceptance by the owner. A letter of acceptance will be provided following the satisfactory completion of all final punch list items.
- D. Rejected plants shall be immediately removed and replaced with a plant meeting the original specification.

PART 2 - PRODUCTS

2.1 TREE AND SHRUB MATERIAL

- A. General: Furnish nursery-grown trees and shrubs conforming to ANSI Z60.1, with healthy root systems. Provide well-shaped, fully branched, healthy vigorous stock free of disease, insects, eggs, larvae and defects such as knots, sun scald, injuries, abrasions and disfigurement.
- B. Grade: Provide trees and shrubs of sizes and specifications identified and conforming to ANSI Z60.1 for type of trees and shrubs specified on the plan and noted in the plant list. Larger sizes may be substituted for the sizes specified if approved by the landscape architect. Larger sizes shall have proportionate increase in size of root ball or container and be provided without increase in contract price.
- C. Label at least one (1) tree and one (1) shrub of each variety with a securely attached, water-proof tag bearing the legible botanical and common name of the plant.
- D. All Shrub, Groundcover, Specialty and Bedding Plants shall be container grown meeting ANSI Z60.1 limitations for container stock.

2.2 GROUNDCOVERS AND PLANTS

- A. Provide groundcover and plants established and well rooted in removable containers with not less than the minimum number and length of runners required by ANSI Z60.1 for the pot size specified.

2.3 TOPSOIL

- A. Topsoil shall meet ASTM D 5268, having a pH range of 5.5 to 7.0, four percent (4%) organic material minimum, free of stones above 1/2" or larger in any dimension, roots, sticks, debris or any other extraneous material harmful to plant growth. Import topsoil shall be from naturally well-drained sites where topsoil occurs at least 4 inches deep. Do not obtain topsoil from bogs or marshes.

2.4 SOIL AMENDMENTS

- A. Lime: ASTM 602, class T, agricultural limestone containing a minimum eighty percent (80%) calcium carbonate equivalent, with a minimum ninety-nine percent (99%) passing a No. 8 sieve and a minimum of seventy-five percent (75%) passing a No. 60 sieve.
 1. Provide lime in the form of dolomitic limestone.
- B. Aluminum Sulfate: Commercial grade, unadulterated.
- C. Sand: clean, washed, natural, free of toxic materials.
- D. Perlite: Horticultural perlite, soil amendment grade.
- E. Peat Humus: Finely divided or granular texture, with a pH range of 6 to 7.5, composed of partially decomposed peat moss (other than sphagnum), peat humus or reed-sedge peat.
- F. Manure: Well-rotted, unleached stable or cattle manure containing not more than twenty-five percent (25%) by volume of straw, sawdust or other bedding materials; free of toxic substances, stones, sticks, soil, weed seed and material harmful to plant growth.
- G. Compost: Native organic compost primarily comprised of leaf matter with wood fines and grass clippings that are decomposed with a pH range of 6 to 7.5
- H. Herbicides: EPA registered and approved, of type recommended by manufacturer. Caution is the bye-word in using any chemical herbicide. Carefully read (and follow) label directions not only for application but also for the plants on which the product may be used (insure that the plant will not be harmed by application). The herbicide user will be held responsible for damage to neighboring properties resulting from improper use or drift. For serious weed problems consider commercial herbicide applicator.
 1. Apply pre-emergent Herbicide to all bed areas a minimum of two (2) weeks prior to planting.
 - I. Water: Potable
 - J. BioPlex 4-in-1 planting granules to be used for plant establishment of trees, shrubs, groundcovers, and plants. Available from BioPlex (800)441-3573.

2.5 FERTILIZER

- A. Bonemeal: Commercial, raw, finely ground; minimum of four percent (4%) nitrogen and twenty percent (20%) phosphoric acid.
- B. Superphosphate: Commercial, phosphate mixture, soluble; minimum of twenty percent (20%) available phosphoric acid.
- C. Commercial Fertilizer: (Peters Professional). Commercial grade complete fertilizer of neutral character, consisting of fast and slow release nitrogen, fifty percent (50%) derived from natural organic sources of ureaform, phosphorous and potassium in the following composition: 1lb. per 1000 SF of actual nitrogen, four percent (4%) phosphorous and two (2%) potassium, by weight. Provide in amounts as recommended by soils test.
- D. Slow-Release Fertilizer: (Osmocote) Granular fertilizer consisting of fifty percent (50%) water-insoluble nitrogen, phosphorus and potassium in the following composition: ten percent (10%) nitrogen, ten percent (10%) phosphorous and ten percent (10%) potassium by weight.

2.6 MULCH

- A. Organic Mulch: Free from deleterious material and suitable as a top dressing of trees and shrubs. Provide the following mulch in the areas identified:
 1. Type: Pine Straw - For large areas under pine trees without understorey plantings or naturalized perimeter areas.
 2. Type: Decorative Stone - Decorative Stone mulch for planter areas inside screen lanai as Specified.

2.7 STAKES AND GUYS

- A. Stake and Guy trees and upright shrubs only as necessary where plants have a problem maintaining a plumb position.
- B. Upright Stakes: Rough-sawn, sound, new hardwood or PT Pine, free of knots, holes, cross grain and other defects, 2 inches by 2 inches, length as required to secure plant.
- C. Guy Cable: 5-strand, 3/16-inch diameter, galvanized-steel cable, with zinc-coated turnbuckles, 3-inch lon minimu, with two 3/8-inch galv. eyebolts.
- D. Hose Chafing Guard: Reinforced rubber or plastic hose at least 1/2 inch in diameter, black, cut to lengths required to protect tree trunks from damage.
- E. Flags: Standard surveyor's plastic flagging tape, white, 12" long.

2.8 MISCELLANEOUS MATERIALS

- A. Gravel: N/A
- B. Edging: N/A

PART 3 - EXECUTION

3.1 EXAMINATION

- A. Examine areas to receive landscaping for compliance with requirements and for conditions affecting performance of work of this Section. Do not proceed with installation until unsatisfactory conditions have been corrected.

3.2 PLANTING SOIL PREPARATION

- A. Before mixing, clean topsoil of roots, plants, sod, stones, clay lumps and other extraneous materials harmful to plant growth.
- B. Mix soil amendments and fertilizers with topsoil at rates indicated by soil test. Delay mixing fertilizer if planting does not follow placing of planting soil within a few days.
 1. Amended Soil Mix shall be determined by the soils analysis of the existing site topsoil.
 2. Soil mix shall incorporate BioPlex 4-in-1 Planting Granules at the rates as follows:
 - a. Trees - 4 oz. (1/4 lb.) per each 1" caliper trunk diameter
 - b. Shrubs - 4 oz. (1/4 lb.) per each 1 gallon size container or 24" of plant height.
 - c. Groundcover - 20 oz. (1-1/4 lb.) per 1000 s.f. of area. Till mix in top 4" of topsoil.
- C. Mix soil amendments and fertilizers with topsoil at rates indicated by soil test. Delay mixing fertilizer if planting will not follow placing of planting soil within 5 days. For bidding purposes only use the following:
 1. Mix thoroughly in a 2:1 ratio:
 - 2 parts original soil removed from plant pit,
 - 1 part amended topsoil,
 2. BioPlex 4-in-1

3.3 PLANTING TREES AND SHRUBS

- A. Planting shall be performed by experienced workmen familiar with planting procedures under the supervision of a qualified supervisor.
- B. Layout of planting areas shall be performed by the contractor in accordance with the planting plans. Contact the landscape architect prior to making any adjustments to the plant layout.
- C. Excavate circular plant pits with vertical sides. Provide shrub pits at least 12" greater than the diameter of the root system. For trees provide a shrub pit at least 3 times greater than the diameter of the root ball. Depth of pit shall accommodate the root system. Plants should be placed on undisturbed compacted soil at a depth that will allow the top of the rootball for a tree or shrub above finish grade. Remove excavated materials from the site.
- D. Place amended soil mixture in the plant pit around the root ball. Water backfill thoroughly to remove air pockets and insure plant is stable in pit.

3.4 GROUNDCOVER PLANTING

- A. Loosen subgrade of planting bed areas to a minimum depth 6 inches. Remove stones larger than 1-1/2 inches in any dimension, sticks, roots, rubbish and other extraneous materials.
- B. Spread 4" of planting mixture over area to be planted. Work mixture into the top 8 inches of the soil. In areas where construction activities have removed all natural planting soil, excavation of all soil to a depth of 8" may be required. Replace soil with planting mix equal to one and one half the amount of soil removed to provide for settling and drainage.

3.5 PALM PLANTING

- A. Palm trees shall be backfilled with native soil.

3.6 GUYING AND STAKING

- A. Guy and Stake trees exceeding 12 feet or more than 2.5 inch caliper immediately after lawn sodding operations unless otherwise indicated. Tree guys shall be temporary and shall be removed before final acceptance by the owner.
- B. Brace all palm trees. Wrap with 5 layers burlap approximately 1/3 of the way up trunk. Attach lumber with cleats and hammer braces to lumber. Secure to ground with stake.

3.7 MULCH

- A. Apply pre-emergent weed killer over grade prior to mulching.
- B. Mulch trees, palms, shrub, groundcover, and planting beds with specified mulching material. Depths of mulch shall be as follows:
 1. Trees, Palms, Shrub beds - 3"
 2. Groundcover and Planting Beds - 3"

3.8 PRUNING

- A. Prune branches of B&B stock, prior to transplanting, to balance the loss of roots and preserve the natural character appropriate to the particular plant requirements.
- B. Prune, thin and shape trees and shrubs according to standard horticultural practice. Prune trees to retain required height and spread. Unless otherwise directed by the Landscape Architect, do not cut tree leaders; remove or cut back broken, damaged and unsymmetrical growth of new wood. Required sizes are sizes after pruning.

3.9 MAINTENANCE

- A. Begin maintaining landscape materials immediately after planting. Maintain all plant material until final acceptance by the owner.
- B. Maintenance shall include but is not limited to mowing, weeding, pruning, fertilizing, watering, and application of appropriate insecticides and fungicides necessary to maintain the plants free of insects and disease.
- C. Re-set settled plants to proper grade and position. Restore planting saucer and adjacent material and remove dead material.
- D. Tighten and repair guys and stakes as required.
- E. Correct defective work immediately after deficiencies become apparent.

3.10 CLEANUP AND PROTECTION

- A. During landscaping, keep pavements clean and work area in an orderly condition.
- B. Protect landscaping from damage due to landscape operations, operations by other contractors and trades, trespassers. Maintain protection during installation and maintenance periods. Treat, repair or replace damaged landscape work as directed.

3.11 DISPOSAL OF SURPLUS AND WASTE MATERIALS

- A. Remove surplus soil and waste material, including excess subsoil, unsuitable soil, trash and debris. Legally dispose of off of owner's property.

3.12 ACCEPTANCE

- A. At the completion of planting work all planted areas will be inspected by the owner's representative to determine if all requirements, including maintenance, have been complied with and plant materials are alive and in healthy, vigorous condition. If all conditions of the contract documents have been met the owner will accept the work.

3.13 WARRANTY

- A. Warrant plant material to remain alive and be in healthy, vigorous condition for a period of 1 year after acceptance by the owner.
- B. Warranty shall not include damage or loss of trees, plants, or groundcover caused by fires, floods, freezing, rains, lightning storms or winds over 75 miles per hour, or negligence on the part of the owner.
- C. Immediately remove and replace all plants found to be dead or in unhealthy condition as determined by the owners representative at any time during the warranty period.

3.14 IRRIGATION REQUIREMENTS

- A. Shallow wells, open surface water bodies or reclaimed water must be used as a source of irrigation water. The distribution system for irrigation must not be connected to county or municipal water sources, unless it can be demonstrated that these sources are not available.
- B. Irrigation systems must utilize low volume design such as low trajectory heads and soaker hoses to provide direct application and low evaporation. Systems that overspray areas that do not require irrigation, such as paved areas will not be acceptable. High irrigation need areas must not overspray low need areas.
- C. High water demand landscape areas such as turf must be served by a separate irrigation zone than low water need areas, such as planter beds, or mulched areas with trees. In no case, shall any planted vegetation area be more than 50' from a water supply hose bib.
- D. Automatic irrigation systems must be operated by an irrigation controller capable of differentiating between the schedules of high and low water demand areas. Controllers must have multiple cycle start capacity and a flexible calendar program able to be set to comply with local or water management district imposed restrictions.
- E. Automatic irrigation systems must be equipped with a rain sensor device or switch which will override the irrigation cycle of the sprinkler system when adequate rainfall has occurred.



Collier County:
7400 Trail Boulevard, Suite 200
Naples, FL 34108
P: 239/777-2333
F: 239/464-2029

CITY OF MARCO ISLAND
50 BALD EAGLE DRIVE
MARCO ISLAND, FL 34145

CLIENT NAME:

MARCO ISLAND
PICKLEBALL CENTER

LANDSCAPE
SPECIFICATIONS

DESIGNED BY: LJA

DRAWN BY: BCG

CHECKED BY: BCG

REVIEWED BY: BCG

HOR. SCALE: N/A

VERT SCALE: N/A

DATE: August 2024

BY:

NO. DATE

REVISIONS:

NO. DATE

ACAD FILE NAME:

Landscape

ABB PROJECT #

23-0019

PILOT VIEW / LAYOUT

L5 SPECS

SHEET

05

OF

07

ACAD FILE #

13639

THESE DRAWINGS DO NOT INCLUDE
COMPONENTS FOR CONSTRUCTION SAFETY.

CALL "SUNSHINE 811" BEFORE DIGGING
Dial 811 or visit www.sunshine811.com

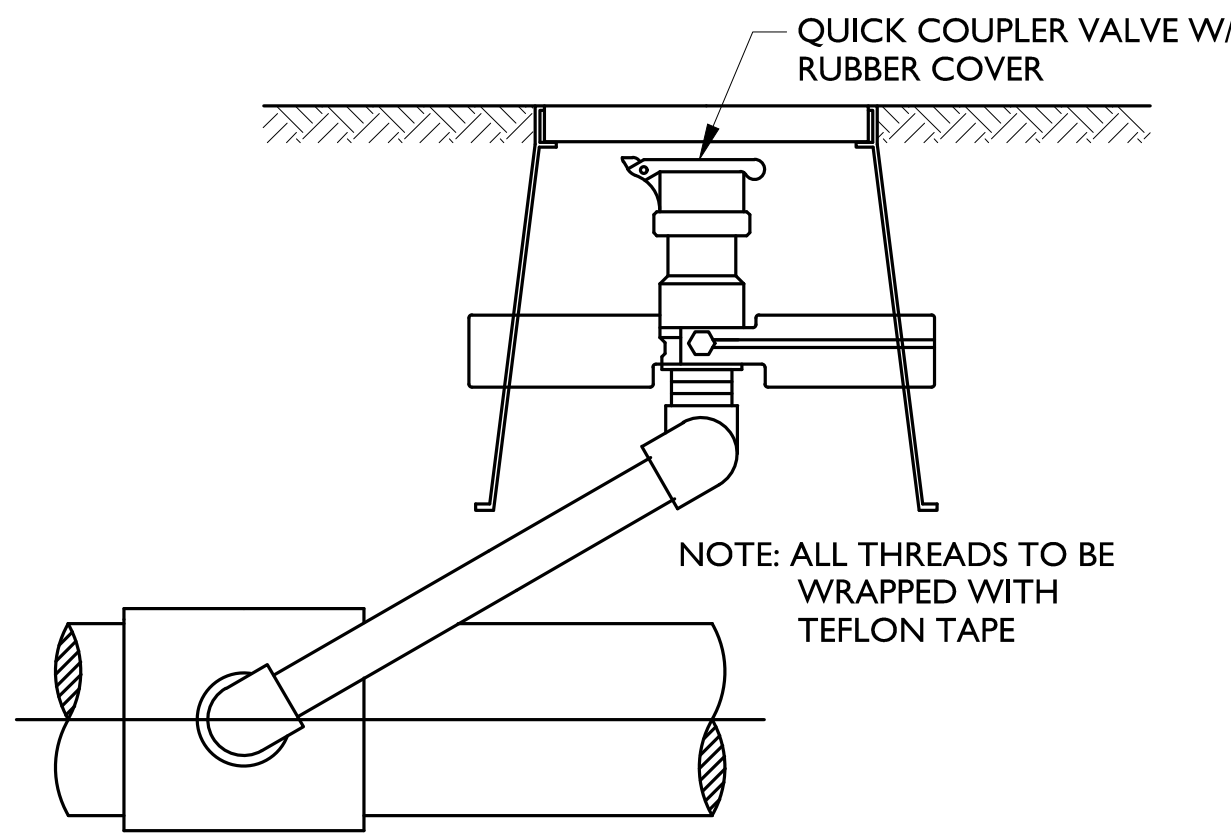

1 Quick Coupling Valve Installation
Scale: N.T.S

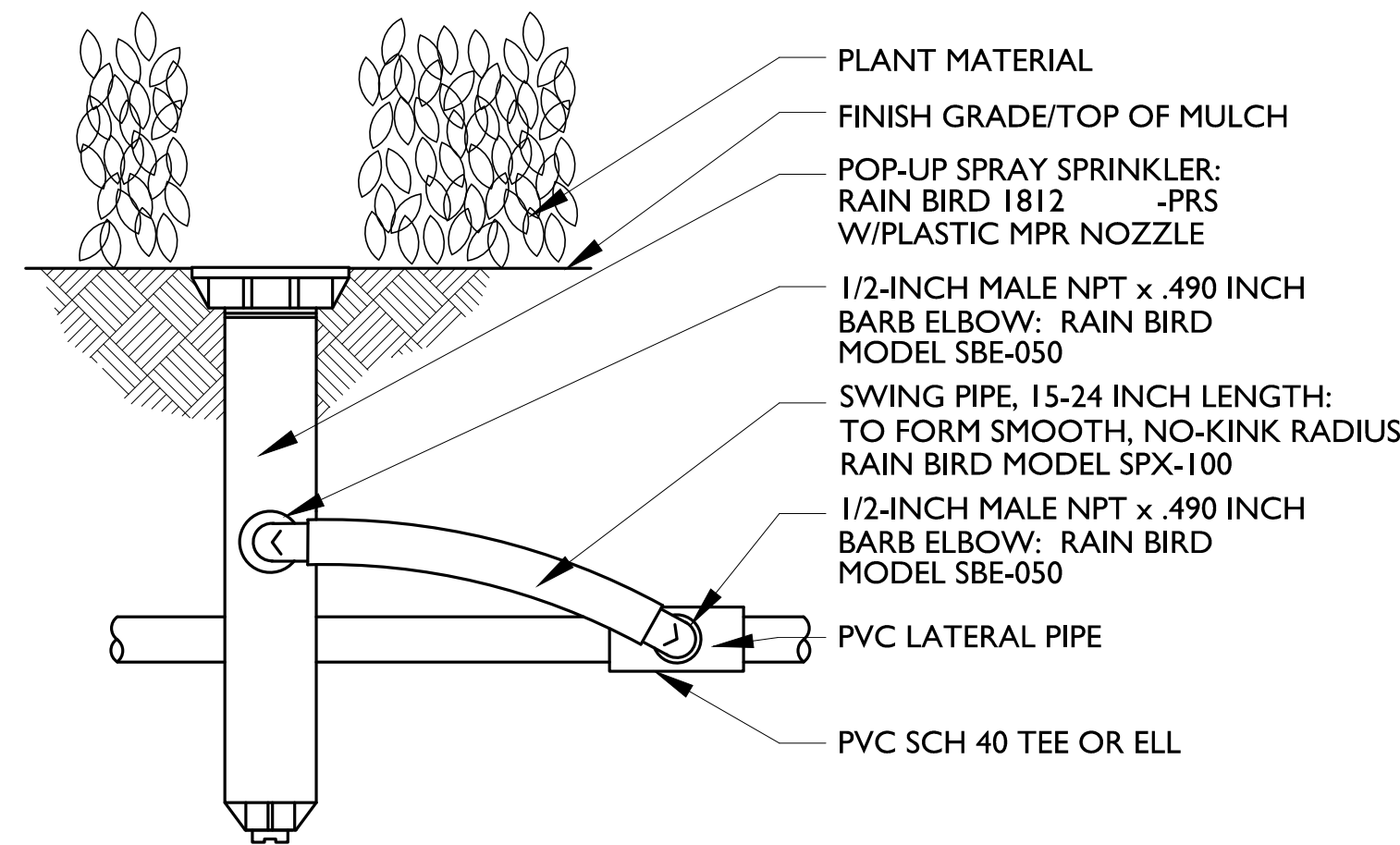

2 12" Pop-up Spray Installation
Scale: N.T.S

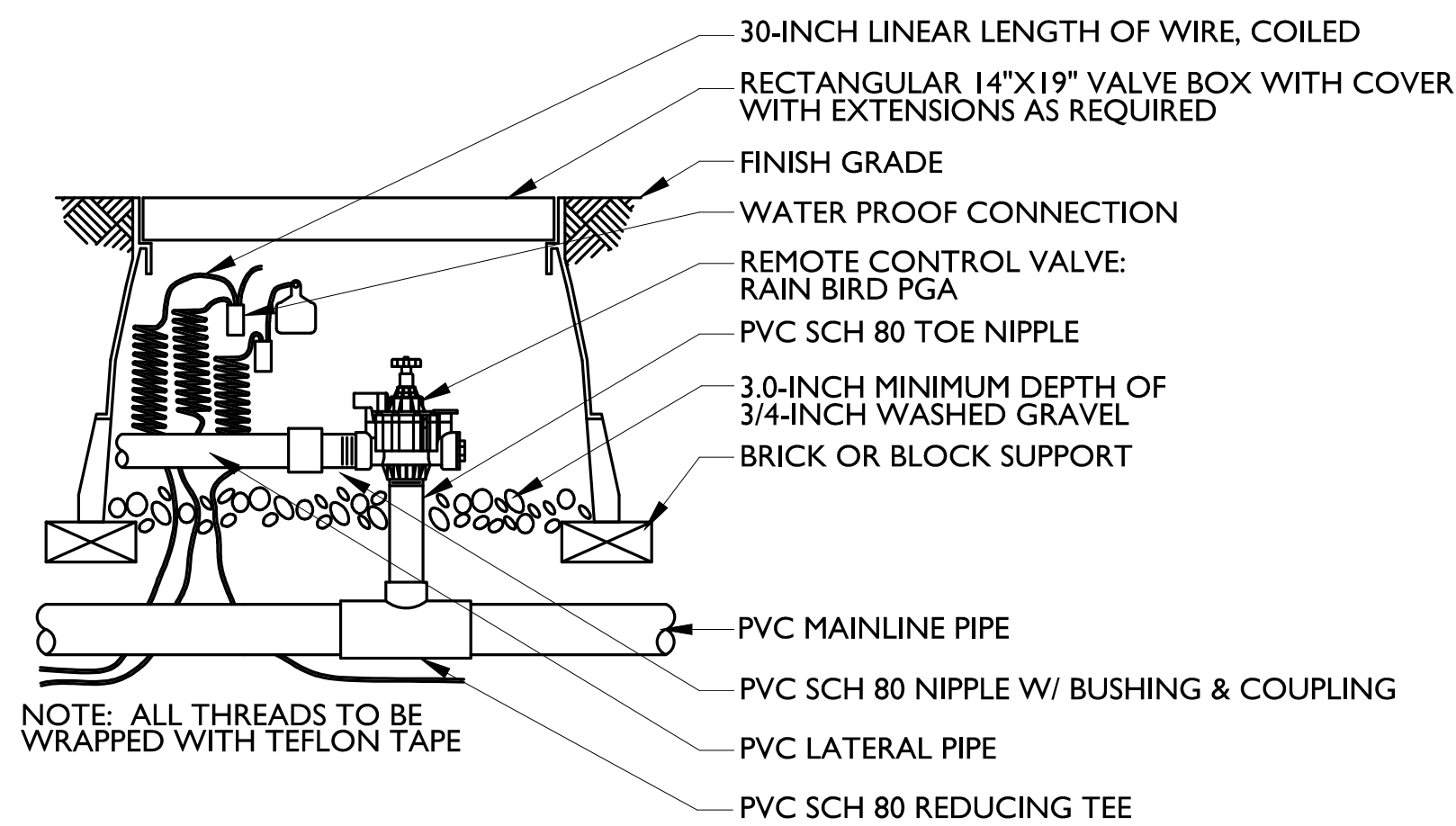

3 Electric Control Valve Installation
Scale: N.T.S

NOTE:
Existing irrigation will be retrofitted as necessary to provide 100% coverage and separation of high and low water use areas.

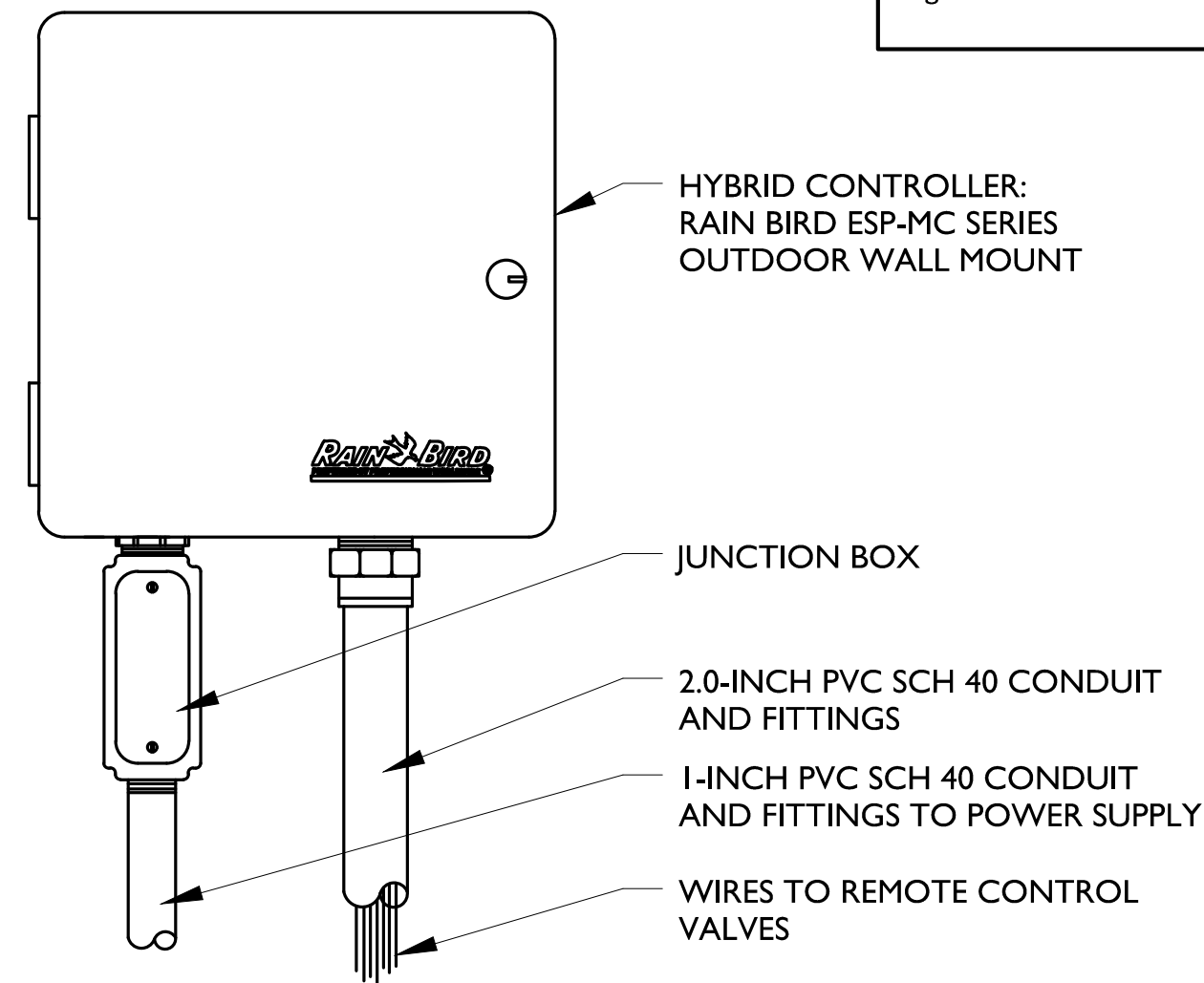

4 Wall Mount Controller Installation
Scale: N.T.S

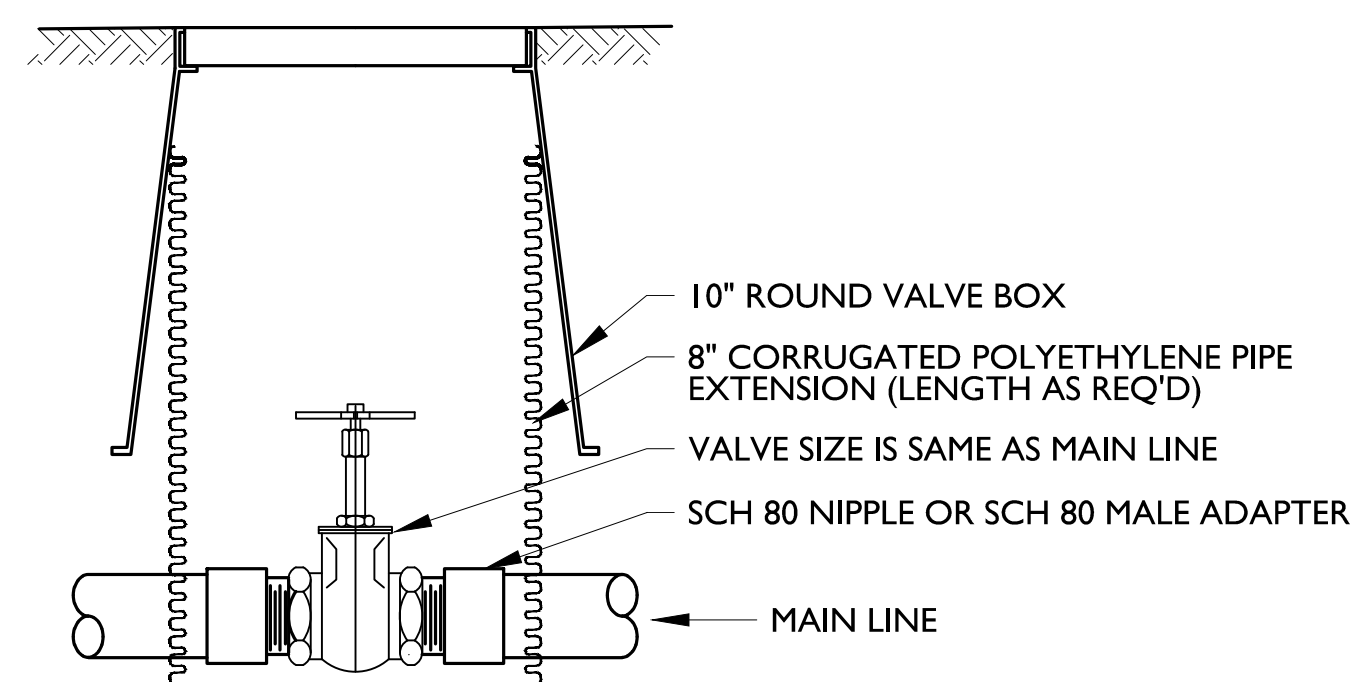

5 Isolation Valve Installation
Scale: N.T.S

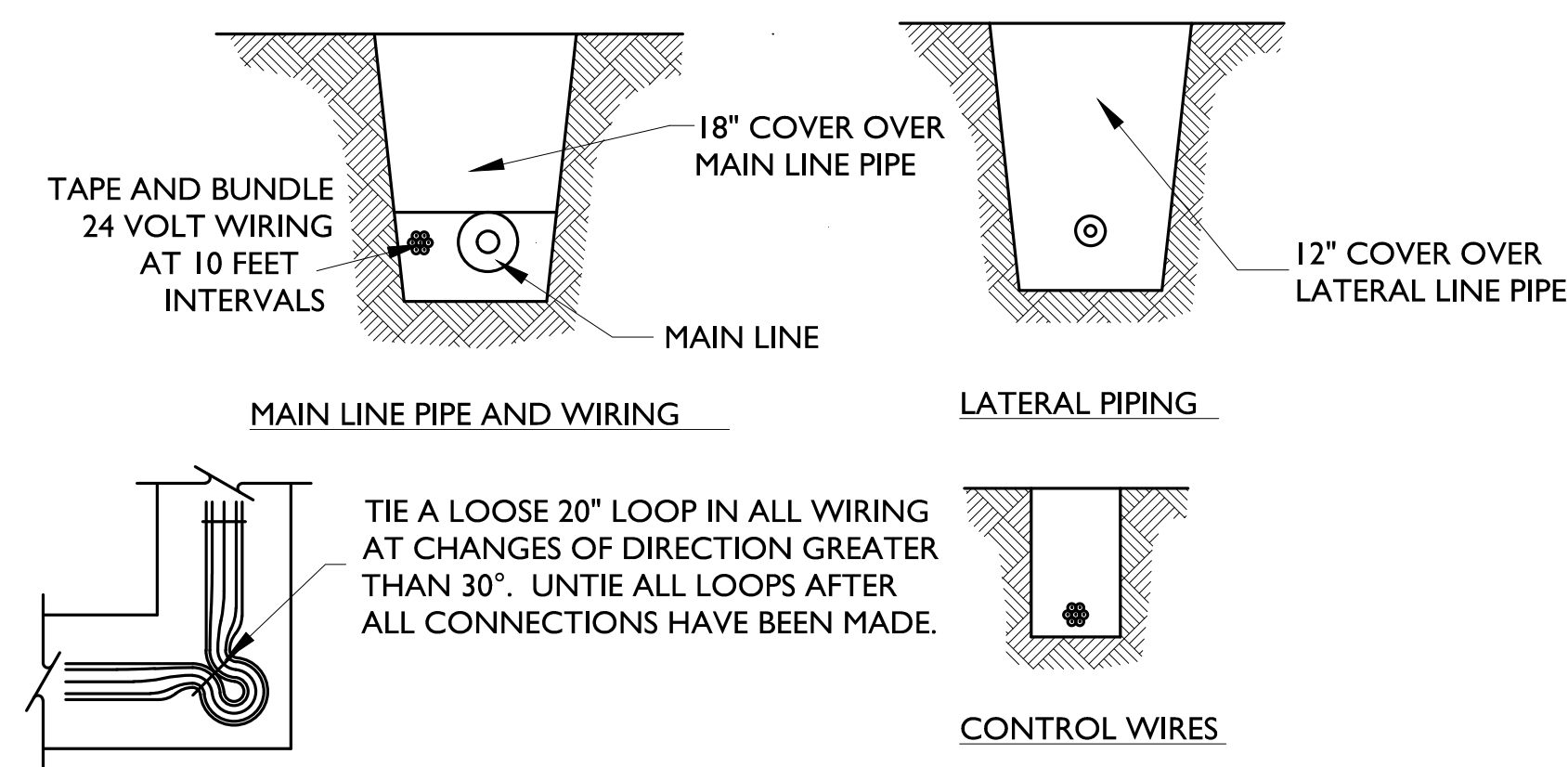

6 Typical Trench Detail
Scale: N.T.S

GENERAL IRRIGATION NOTES

- Prior to excavation, contractor shall verify utility locations with telephone, gas, cable tv, and electric companies. Owner's representative and contractor to review site electrical, site grading and drainage, site irrigation and all other drawings pertaining to underground utility locations.
- Contractor shall measure the static water pressure and shall report to Landscape Architect in writing a minimum of two (2) weeks prior to commencement of irrigation installation. Should static water pressure be less than 50 psi, contractor shall receive approval from Owner prior to proceeding.
- Contractor shall provide full 100% head to head coverage. At no time shall water spray onto concrete footings or pavements.
- Irrigation installation shall be coordinated with excavation, grading, building, paving and planting operations.
- Contractor shall follow drawings, specifications and specific manufacturers recommendations to insure proper installation of the irrigation system. Contractor shall notify Owner in writing whenever there appears to be a conflict between any of the above stated documents. Contractor shall submit to the Landscape Architect a complete set of shop drawings prior to the implementation of the irrigation system. Contractor shall not begin construction of the irrigation system until approval is granted by the Landscape Architect.
- Controller shall be installed at the Owner-approved location. The irrigation controller shall be installed according to manufacturer's recommendations. Controller shall be installed on a minimum 6" reinforced concrete slab or as recommended by the manufacturer. Contractor is responsible for the supply and connection of 120 volt power to the controllers.
- One (1) rain sensor shall be installed at the Owner-approved location. To insure proper operation and protection of the sensor, sensor shall be installed according to manufacturer's recommendations. Contractor shall receive owner's approval for acceptable location prior to installation of the sensor.
- Irrigation 24 volt common wire shall be 14 gauge and control wire shall be 14 gauge if.
- All valves are to be installed in valve boxes. Contractor is encouraged to manifold valves where possible to minimize the amount of individual valve boxes. Electric controlled valves shall be installed in a 24" x 18" rectangular box. Isolation valves shall be installed in a 10" round valve box. Contractor shall not install more than two (2) valves in a 24" x 18" rectangular valve box.
- When installing threaded products, Contractor shall use manufacturer's recommended sealing compounds and/or teflon tape according to manufacturer's recommended practice for the specific application.
- Contractor shall install all valve and common wiring beneath the irrigation main and/or laterals.
- Contractor shall carefully backfill all trenches with the excavated material approved for backfilling, consisting of earth, loam, sandy clay, sand, soft shale, or other approved materials, free from large clods of earth or stone, sharp objects, rock, broken concrete or pavement, and large boulders shall not be used as backfill material.
- The Contractor shall be responsible for constructing the system in complete accordance with all applicable codes ordinances and laws. Any modifications made to conform with said codes, laws and ordinances shall be completed at the Contractor's expense at no additional cost to the Owner.
- The Contractor shall provide as-built drawings on a stable mylar, showing all heads, valves, and pipe lines to scale after completion of piping installation. The Contractor shall provide instruction sheets and parts list covering equipment.
- The irrigation contractor is fully responsible for the work until the Owner gives final acceptance. Contractor will guarantee the quality of his materials and work for one (1) year. This period begins with the final acceptance of the Owner.
- The Contractor is responsible for providing a complete and operable system for the irrigation of all landscape planting on site. Plans and specifications may not indicate all items necessary for the proper irrigation of the project and the contractor holds the responsibility for furnishing labor, materials and equipment required for a complete and proper project even if not in the initial specifications.
- Contractor to modify proposed design to account for actual gpm and psi.
- Contractor to modify proposed design to account for actual field conditions.

SITE IRRIGATION NOTES

- Landscape contractor to provide 100% coverage for all areas (including lawn).
- The irrigation system shall be designed and installed to ensure that full and adequate water coverage occurs.
- All above ground irrigation back-flow preventers/check valves shall be screened with plant material so that they are not visible.
- Contractor shall adjust heads and spray as necessary to minimize overspray and ensure proper bed coverage. 5. All PVC pipe to be sized so water does not exceed 5' per second.
- Contractor is to provide a full and functional irrigation system.
- Two (2) spare wires shall be provided to all electrical valves for future use.
- Open lawn areas and all other turf shall be on a separate zone than that of shrubs and groundcovers.
- All trees to have bubblers provided on a separate zone.
- Irrigation water shall be non-potable.
- A back flow preventor will only be necessary if potable water is used for irrigation. Back flow preventor to be provided by Owner / Builder.
- A rain sensor shall be installed on the irrigation system in an area free of overhead obstructions.
- All secondary (circuit) irrigation lines 1 inch diameter to 3 inch diameter shall be class 160 pvc. Circuit water lines 1/2 inch to 3/4 inch diameter shall be class 315 pvc. Secondary irrigation lines shall be installed within the landscaped area at a minimum depth of 12 inches. pop-up sprinkler heads must be utilized within any movable area. However, in no case may sprinkler heads nor secondary lines be installed within 1 foot of the back of roadway curb or on the front slope and ditch bottom of swale sections.
- The irrigation contractor shall review the planting plans to determine the proposed plant materials for each head location prior to bidding. The irrigation contractor shall be responsible for modifying head installation types, depending on the final locations of all plant material.
- All sprinkler heads are to be installed with a 18 inch minimum length flexible pvc pipe, using standard pvc fittings.
- All heads shall be adjusted to reduce water waste on hard surfaces and walls.
- The irrigation contractor is responsible for furnishing and installation of sleeves under pavements and all roadways as shown on the plans. The irrigation contractor shall coordinate sleeve locations with project superintendent prior to installation.
- The irrigation contractor shall exercise care so as not to damage existing utilities. The irrigation contractor shall be responsible for determining the location of all underground utilities. The irrigation contractor shall repair or replace all items damaged as a result of his or her work.
- All low voltage direct buried wiring shall be ul approved, type ul and a minimum size of #14 awg. The common wire shall be white and all wiring shall be the same color from controller valve. One spare wire shall be run along entire length of the mainline then terminate at the controller. All splices shall be in a valve or splice box. Provide 48 inch expansion coils at all valves. All splices shall be made with 3m-df4.
- All irrigation lines crossing beneath roadways shall be encased in schedule 40 pvc, as shown on the plans. Sleeves shall be a minimum of 24 inches below edge of pavement surface, 18 inches depth within the right-of-way, and installed 90 degrees to roadway centerline. Subsequent installations shall be jack and bore. Contractor shall at all times block ends of sleeves to prevent buildup of sediment within sleeves.
- All primary (main) irrigation lines shall be schedule 40 pvc, installed in sleeves 24 inches below pavement and 18 inches below ground surface outside of roadway crossings.
- All piping under constant pressure shall be tested under hydrostatic pressure of not less than 100 p.s.i. for one hour with no more than 5 psi loss.
- Irrigation contractor shall be responsible for the complete installation and electrical connection to the irrigation controllers.
- The rain sensor shall be located in an area where no overhead obstructions that will alter rain fall or produce debris that may invalidate rainfall readings.
- Refer to landscape drawings when trenching to avoid existing and proposed trees and shrubs. Hand digging shall be used beneath canopies of trees to avoid damaging roots. The irrigation contractor shall verify that the quantities indicated will provide the coverage as specified and report any discrepancies at time of bidding to the Landscape Architect.

PROJECT IRRIGATION NOTES

- Irrigation Contractor responsible for field locating existing mainline, wire and lateral piping.
- Connection into existing system to be adjusted as necessary based on conditions in the field, to provide fully operational system. Prior to beginning work, the existing system shall be operated by the contractor to determine the actual extent of the system.
- Remove irrigation zone lines and heads within the construction boundary only. All components outside of the construction boundary are to remain in service, as is.
- Irrigation Contractor responsible for relocating and capping existing lines as necessary prior to new construction. Extend lines as necessary and stub above ground for future connection.
- Zone lines within the construction boundary that supply other areas shall be rerouted as required, and reconnected to their original valves, or to new valves on the existing system, as appropriate. These new lines may remain within the construction boundary, but shall be routed so that they are accessible after construction is complete.
- All components removed shall be disposed of properly and not reused.
- Irrigation Contractor to coordinate sleeve installation with General Contractor.
- Disturbance to existing trees and plant material, as by trenching, shall be minimized.
- Points of connection to be determined in the field. Irrigation Contractor shall verify points of connection can provide 60 gpm @ 55 psi.

Coverage Detail

Irrigation heads shall be placed so that they provide head - to - head coverage. 100% overlap

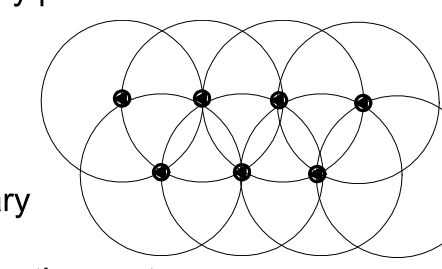

If Irrigation Water is to be non-potable no back-flow preventer is required. A Backflow preventer will only be necessary if potable water is used for irrigation. A Rain sensor shall be installed on the irrigation system.

THESE DRAWINGS DO NOT INCLUDE COMPONENTS FOR CONSTRUCTION SAFETY.
CALL "SUNSHINE 811" BEFORE DIGGING
Dial 811 or visit www.sunshine811.com

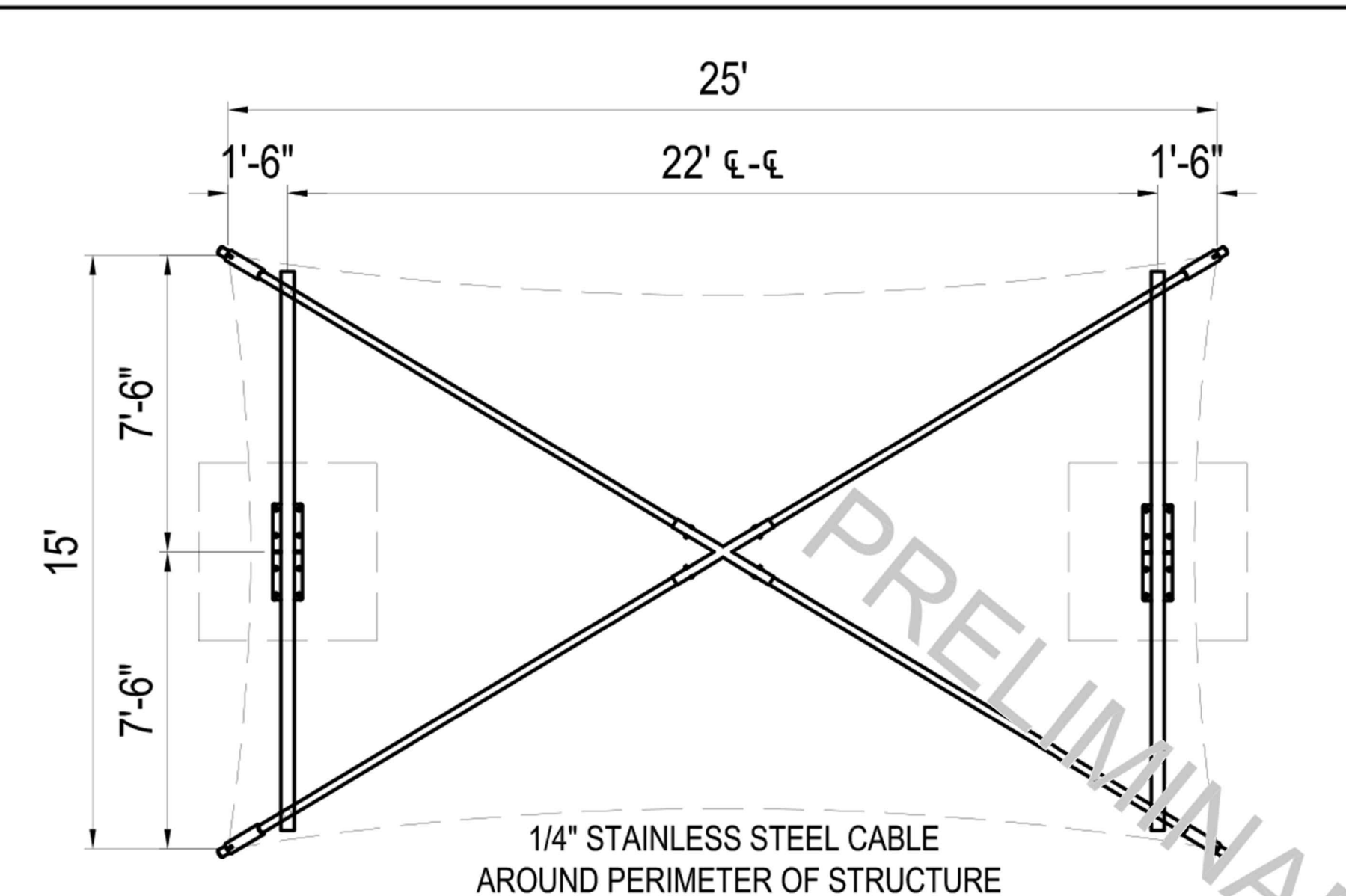

1 PLAN VIEW

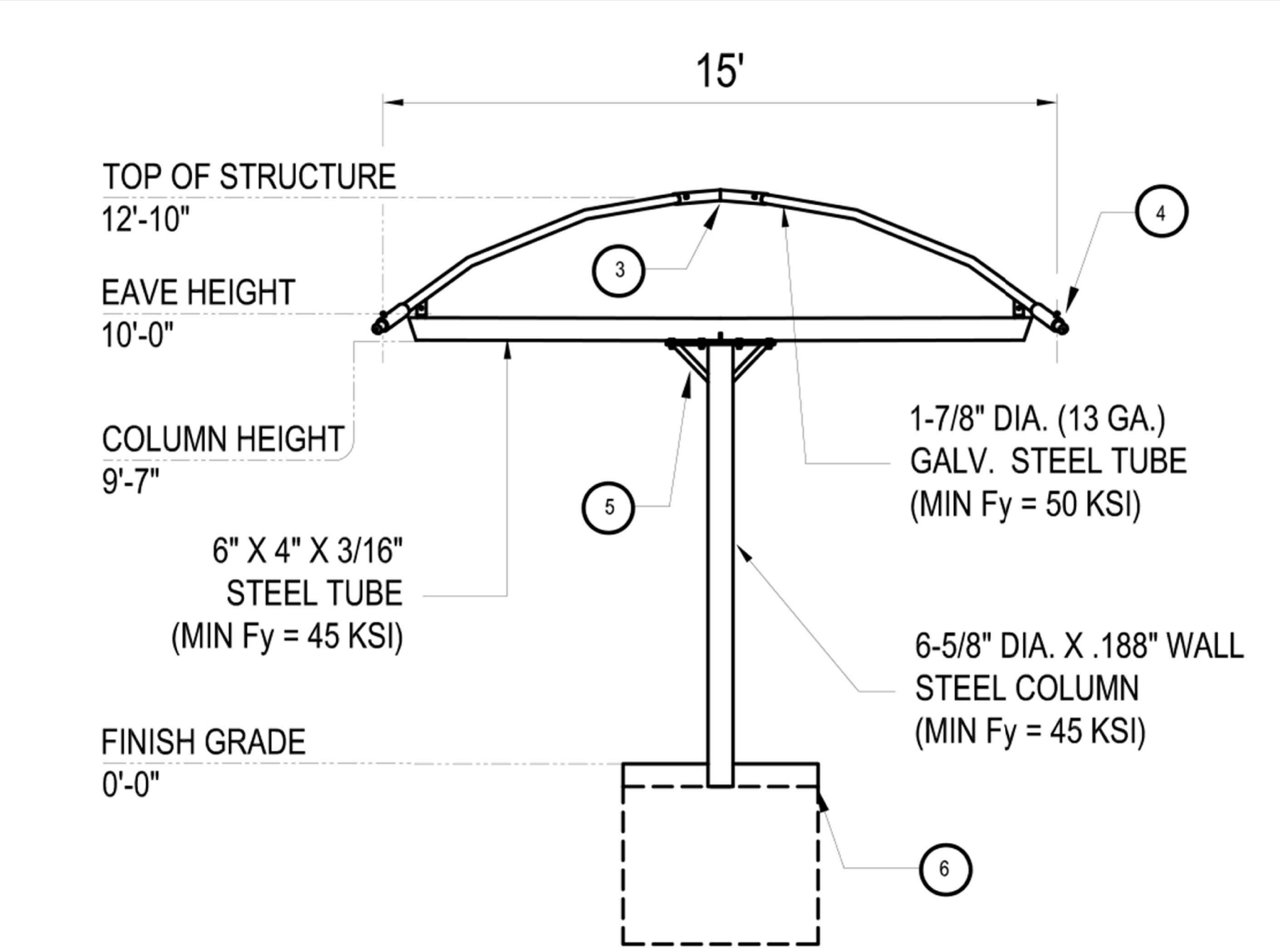

2 ELEVATION VIEW

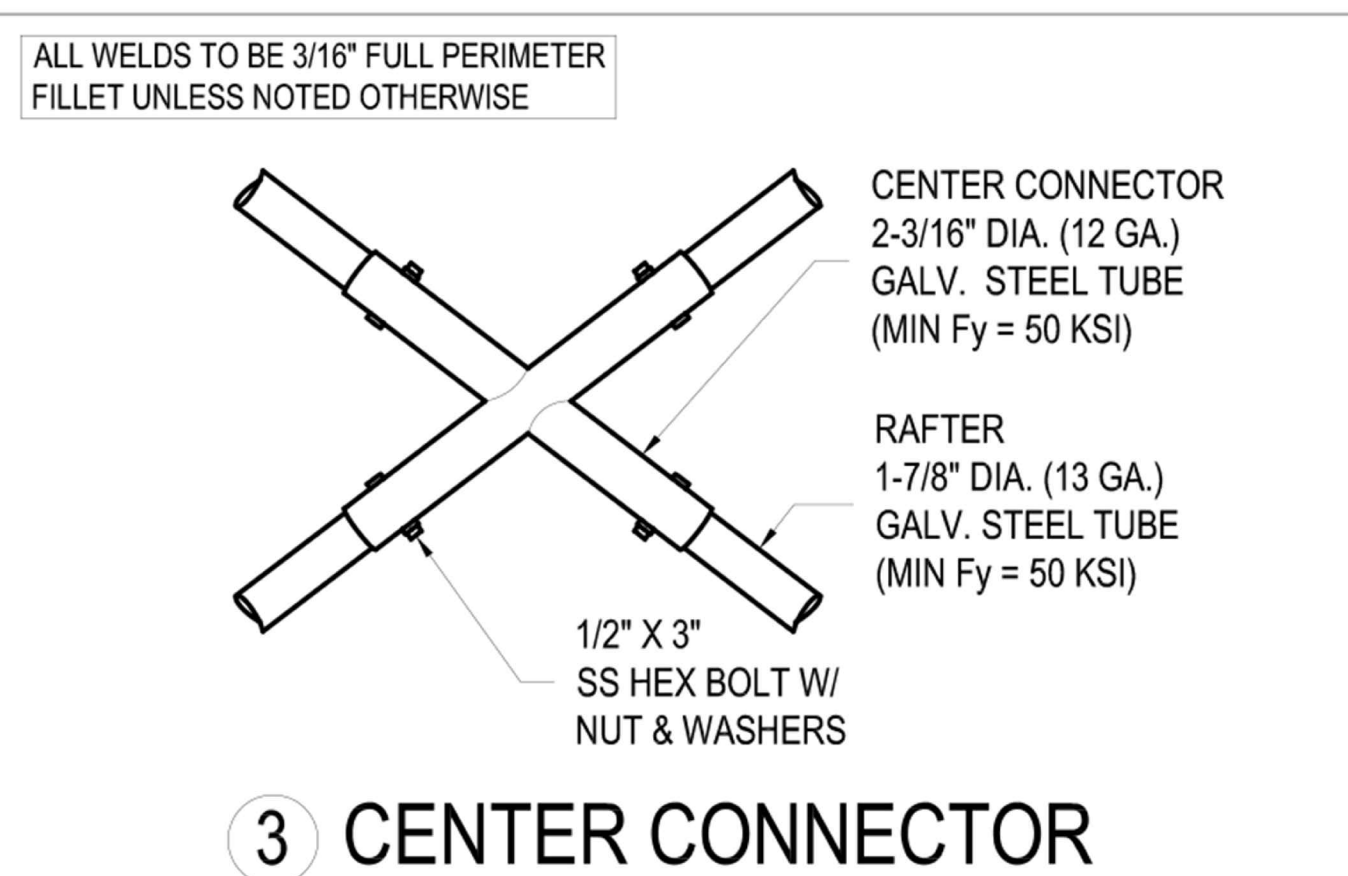

3 CENTER CONNECTOR

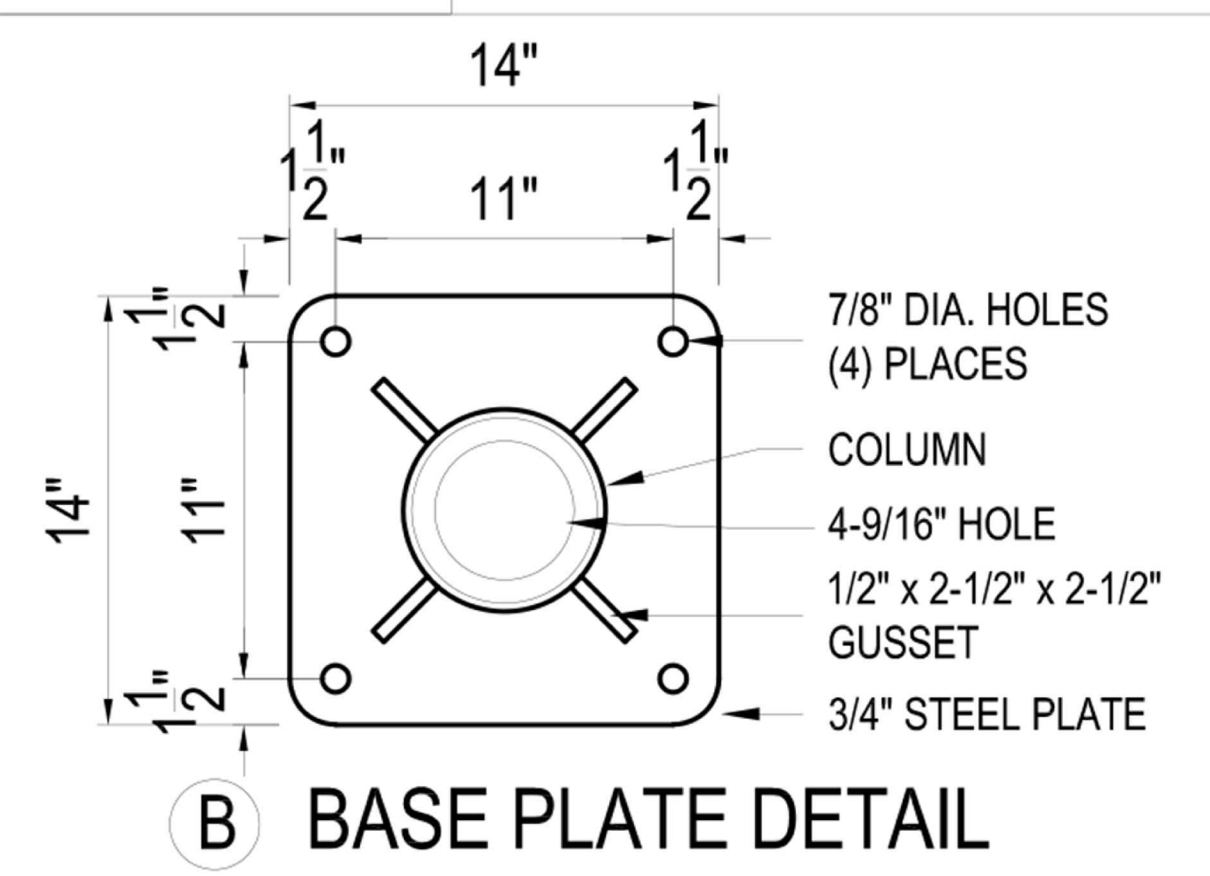

B BASE PLATE DETAIL

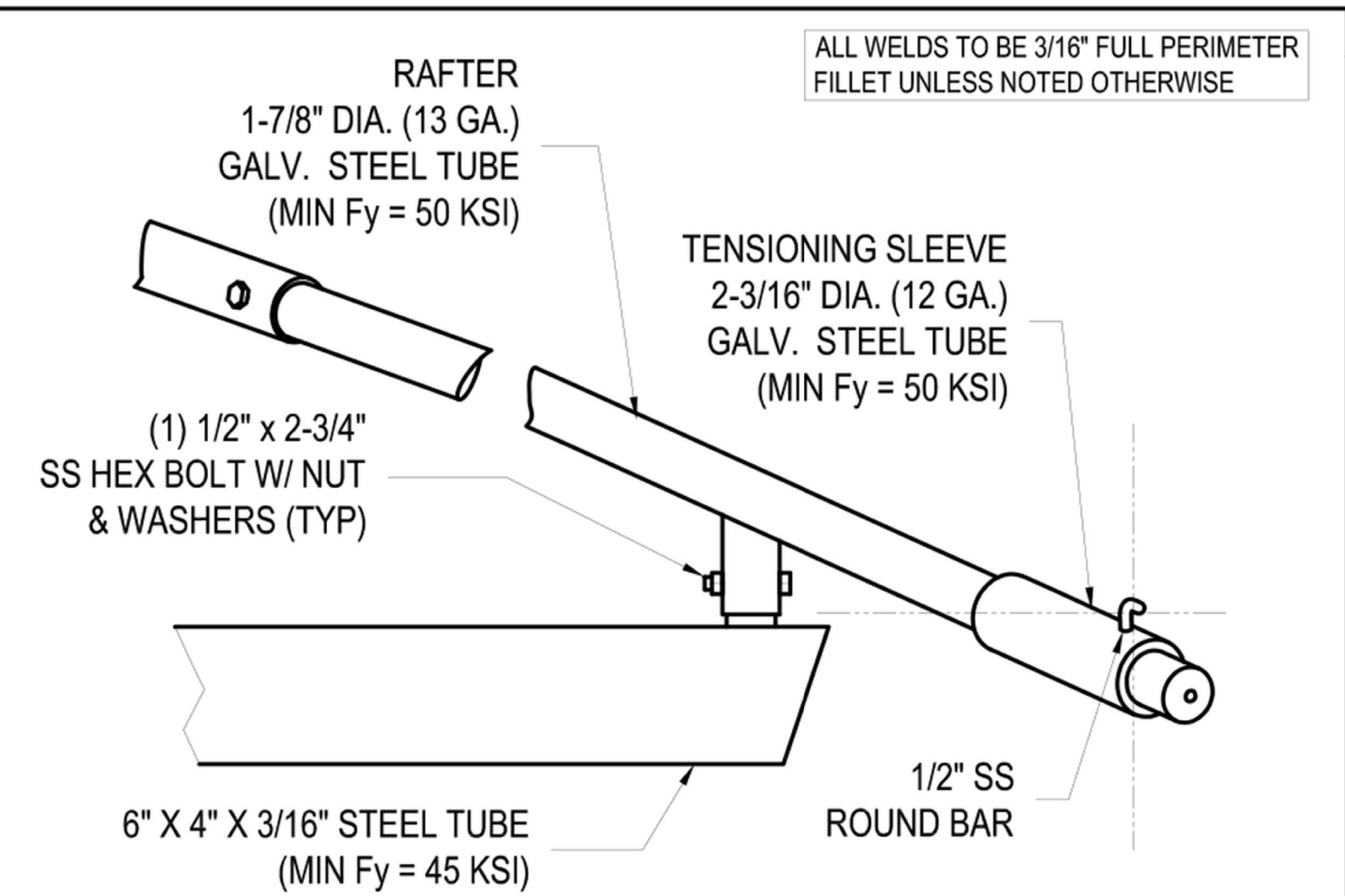

4 RAFTER-BEAM CONNECTION DETAIL

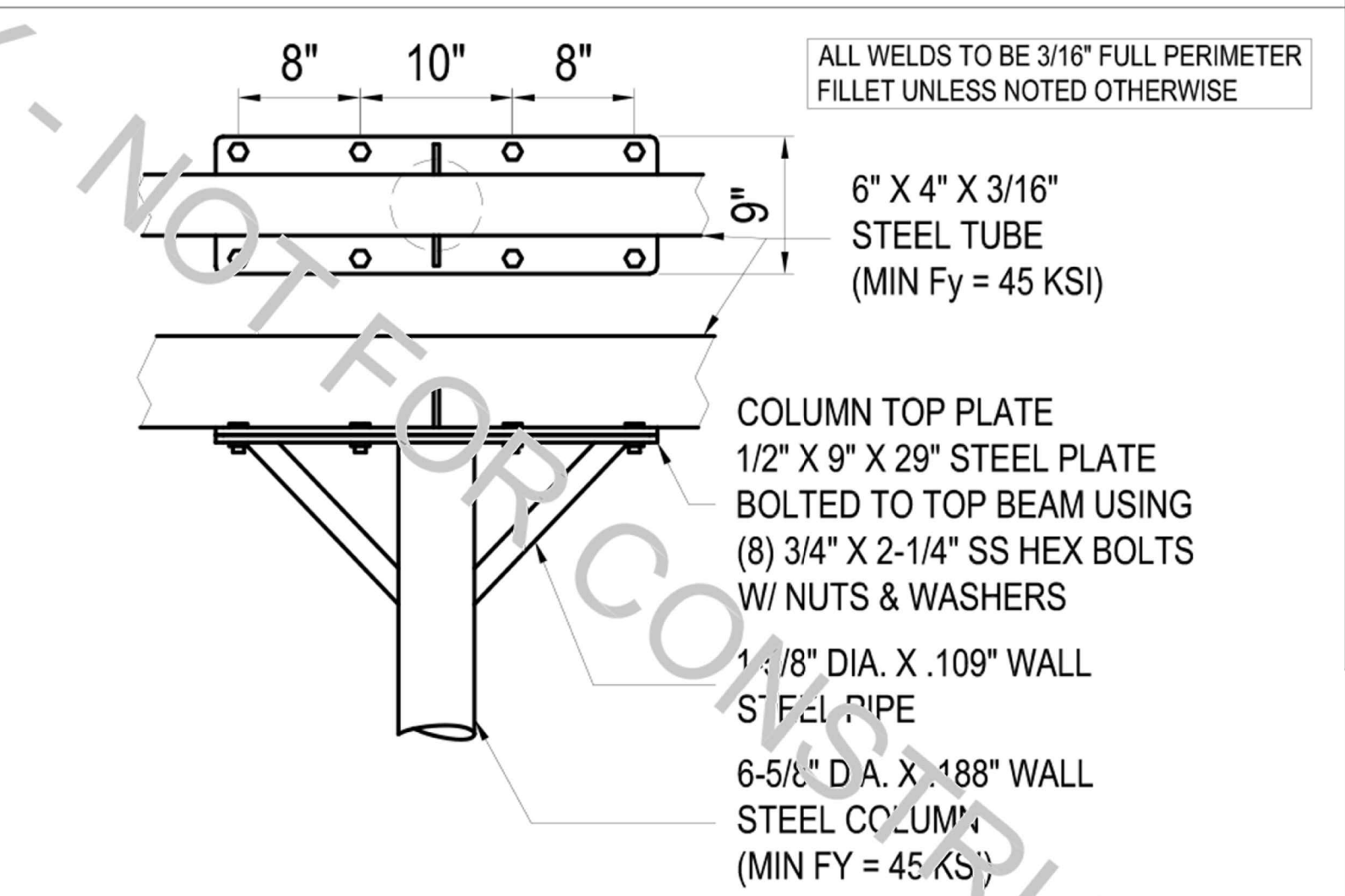

5 BEAM-COLUMN CONNECTION DETAIL

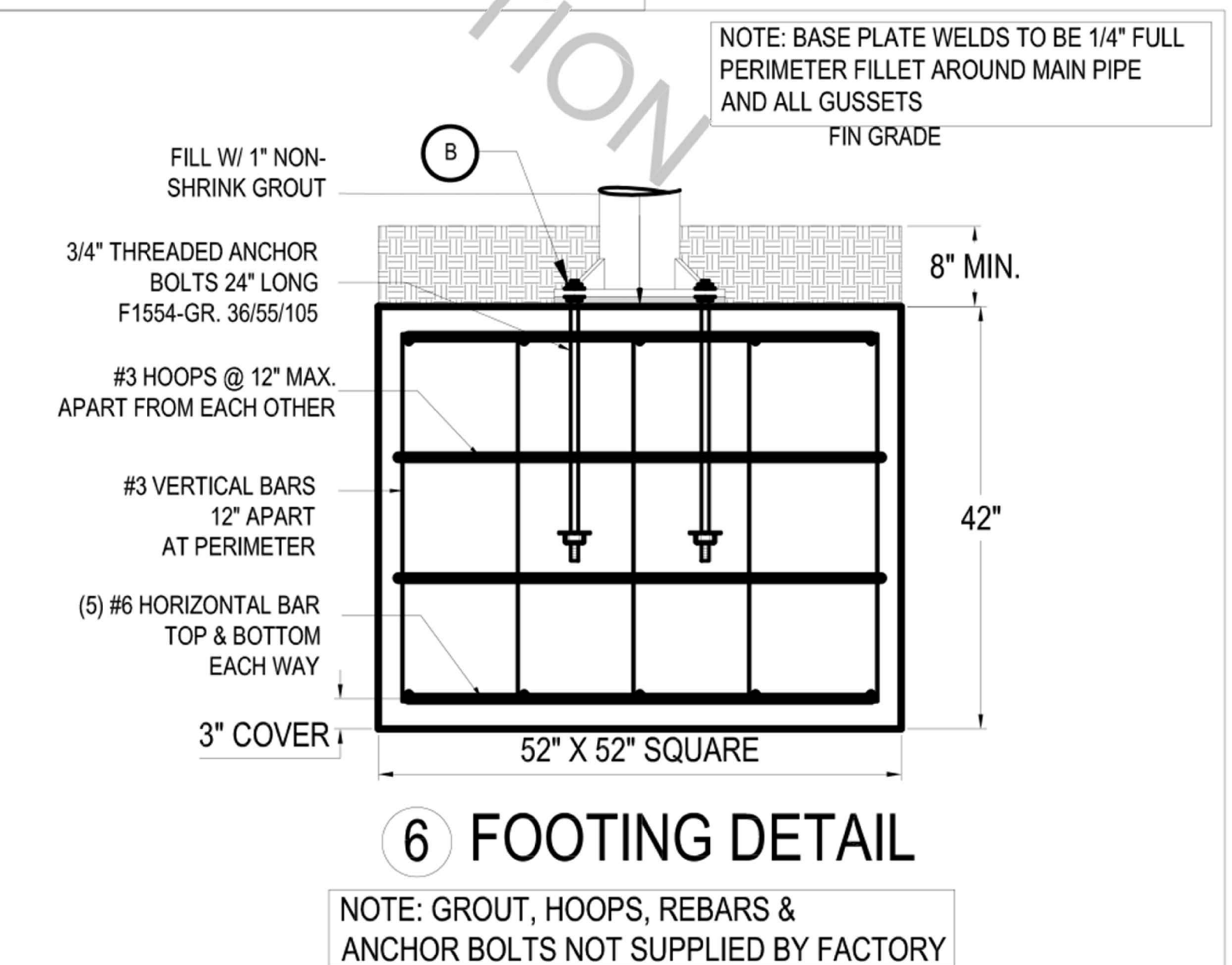

6 FOOTING DETAIL

NOTE: GROUT, HOOPS, REBARS &
ANCHOR BOLTS NOT SUPPLIED BY FACTORY

GENERAL NOTES

1- THE SHADE SYSTEMS, INC.™ STRUCTURE HAS BEEN DESIGNED IN ACCORDANCE WITH THE 2023 FLORIDA BUILDING CODE 8TH EDITION AND ASCE 7-16 TO THE FOLLOWING DESIGN CRITERIA:

CATEGORY	STRUCTURE WITH FABRIC CANOPY REMOVED
EXPOSURE	C
BASIC WIND SPEED	165 MPH

2- THE FOUNDATION ASSUMES A MINIMUM SOIL BEARING CAPACITY OF 1700 PSF.

3- ALL FASTENERS SHALL BE STAINLESS STEEL.

4- ALL BOLTS MUST BE SNUG TIGHT. THE SNUG TIGHTENED CONDITION IS THE TIGHTNESS THAT IS ATTAINED WITH THE FULL EFFORT OF A TYPICAL WORKER USING AN ORDINARY SPUD WRENCH TO BRING THE PILES INTO FIRM CONTACT. SNUG TIGHT IS THE CONDITION THAT EXISTS WHEN ALL THE PILES IN A CONNECTION HAVE BEEN PULLED INTO FIRM CONTACT BY THE BOLTS IN THE JOINT AND ALL THE BOLTS IN THE JOINT HAVE BEEN TIGHTENED SUFFICIENTLY TO PREVENT THE REMOVAL OF THE NUTS WITHOUT THE USE OF A WRENCH.

5- THE FABRIC SYSTEM IS DESIGNED TO WITHSTAND WINDS UP TO 90 MPH WITH THE FABRIC ATTACHED. HOWEVER THE FABRIC MAY NOT WITHSTAND WINDS IN EXCESS OF 90 MPH AND THEREFORE RELEASE.

STEEL:

1- STEEL PIPES SHALL HAVE A MINIMUM YIELD STRENGTH OF 45 KSI. STEEL PLATES SHALL CONFORM TO ASTM A36.

2- ALL PARTS SHALL BE FACTORY-WELDED TO AMERICAN WELDING SOCIETY (AWS) SPECIFICATIONS AND SHALL UTILIZE E70-S6 AND HAVE THE HIGHEST STANDARDS OF QUALITY WORKMANSHIP.

3- ALL WELDS SHALL BE FILLET WELDS WITH MAXIMUM PERMISSIBLE THROAT THICKNESS OR FULL PENETRATION GROOVE WELDS.

CONCRETE:

1- ALL CONCRETE SHALL BE MIXED AND PLACED IN ACCORDANCE WITH THE LATEST EDITION OF ACI 301 AND 318.

2- CONCRETE SHALL HAVE A MINIMUM 28 DAY COMPRESSIVE STRENGTH (f_c) OF 3000 PSI. A CONCRETE MIX HAVING A LISTED STRENGTH OF AT LEAST 3000 PSI THAT IS MIXED IN ACCORDANCE WITH THE MANUFACTURER'S RECOMMENDATIONS IS ACCEPTABLE FOR USE.

3- REINFORCING STEEL SHALL BE ASTM A-615 GRADE 60 WITH A MINIMUM YIELD STRENGTH (f_y) OF 60 KSI.

4- UNLESS OTHERWISE SHOWN, CONCRETE COVER SHALL BE 3" (MIN).

FABRIC:

1- COOLNET™ SHADE FABRICS MEET FIRE STANDARDS FOR SHADE FABRICS INCLUDING CFSM 1237.1 AND NFPA 701 ACROSS ALL COLOR VARIANTS.

THIS DOCUMENT AND ITS CONTENTS ARE THE PROPERTY OF SHADE SYSTEMS, INC. AND CANNOT BE MODIFIED, USED, OR RESOLD TO ANY PERSON OR ENTITY WITHOUT WRITTEN PERMISSION FROM SHADE SYSTEMS, INC. REPRODUCTION OF THESE PLANS, EITHER IN WHOLE OR IN PART, INCLUDING ANY FORM OF COPYING AND/OR PREPARATION OF DERIVATIVE WORKS THEREOF, FOR ANY REASON WITHOUT PRIOR WRITTEN PERMISSION FROM SHADE SYSTEMS, INC. IS STRICTLY PROHIBITED.

© 2024 SHADE SYSTEMS INC.

NOTE TO OWNER:
OWNER ACCEPTS FULL RESPONSIBILITY FOR REMOVING THE FABRIC SHADE MATERIAL FROM THE STEEL FRAME WHEN SEVERE WEATHER CONDITIONS ARE PREDICTED. SUCH CONDITIONS INCLUDE PREDICTED WIND SPEEDS IN EXCESS OF 75 MPH.

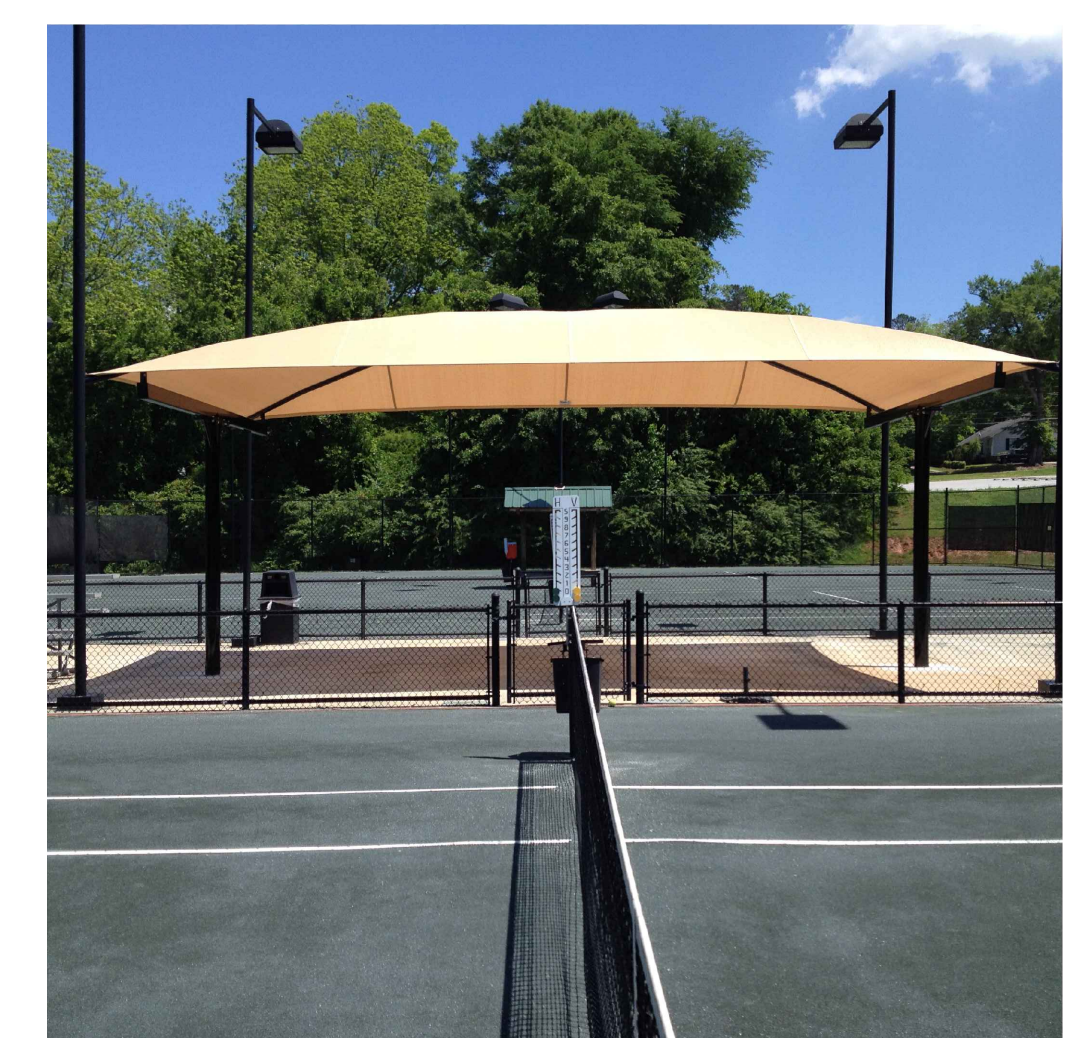
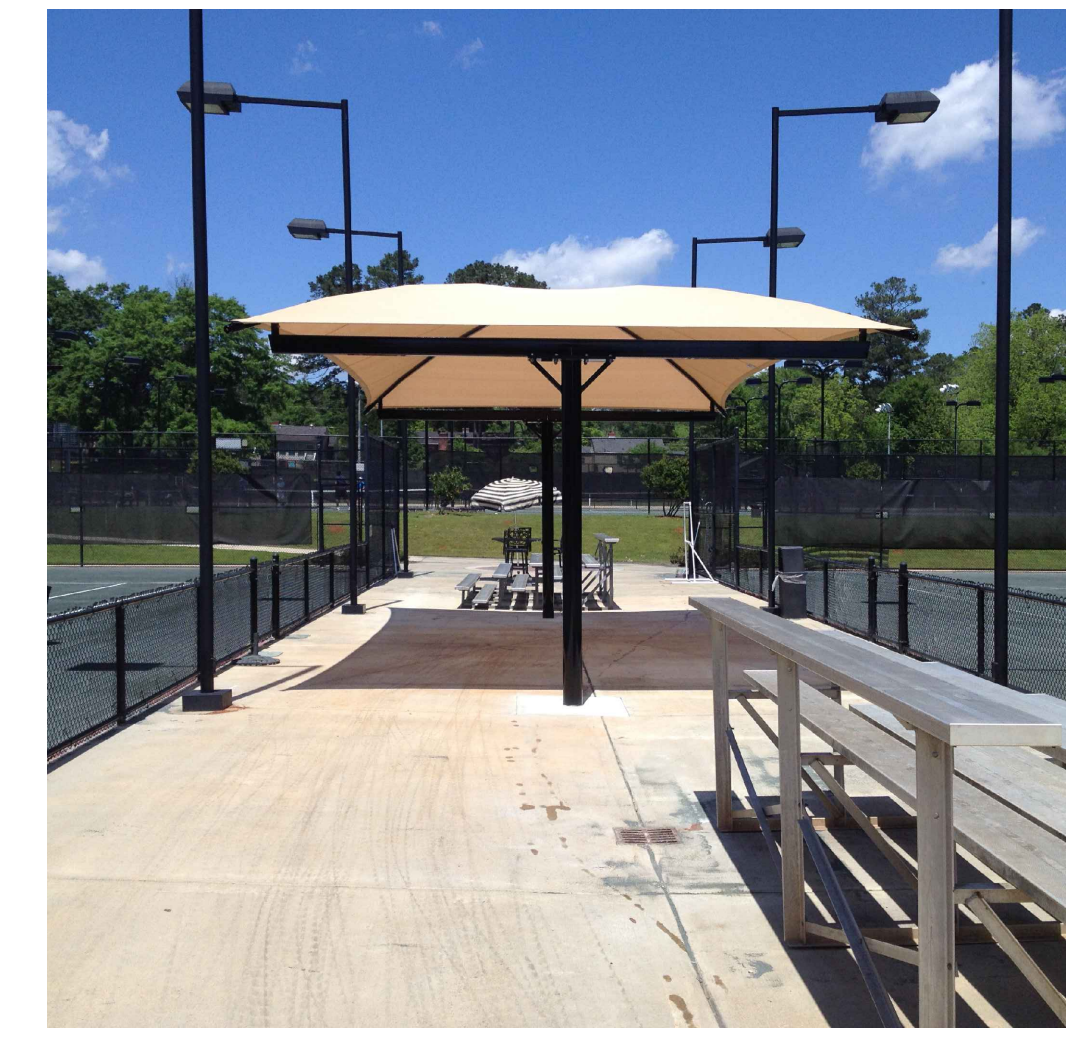

NOTE: Images are provided for reference only.

NOTE: Contractor to provide Certified Shop Drawings for all Shade Canopy Structures.

LJA
EMPLOYEE-OWNED.
CLIENT FOCUSED.
Engineering Firm Number: 31200
Surveying Firm License: LR8669

Collier County:
2600 Trail Boulevard, Suite 200
Naples, FL 34109
P: 239/477-2200
F: 239/477-2203

CLIENT NAME:
CITY OF MARCO ISLAND
50 BALD EAGLE DRIVE
MARCO ISLAND, FL 34145

PROJECT NAME:
MARCO ISLAND
PICKLEBALL CENTER

DRAWING TITLE:
CANOPY DETAILS PLAN

DESIGNED BY: LJA
DRAWN BY: BCG
CHECKED BY: BCG
REVIEWED BY: BCG
HOR. SCALE: Varies
VERT. SCALE: N/A
DATE: August 2024

NO. DATE
REV. No. 1 - Per City Plan Corrections Report dated February 29, 2024

ACAD FILE NAME:
Landscape

ABB PROJECT #
23-0019

PLOT VIEW \ LAYOUT
L7 CANOPY

SHEET 07
OF 07

ACAD FILE #
13639